

# Analog Balancing Tool

Models ABT701/ABT703/ABT711/ABT713

Owner's Manual





TSI INCORPORATED

Product Registration

## Start Seeing the *Benefits* of Registering Today!

Thank you for your TSI instrument purchase. Occasionally, TSI releases information on software updates, product enhancements and new products. By registering your instrument, TSI will be able to send this important information to you.

**<http://register.tsi.com>**

As part of the registration process, you will be asked for your comments on TSI products and services. The **ReliaStat** program gives customers like you a way to tell us how we are doing.

**TSI Incorporated**

USA [www.tsi.com](http://www.tsi.com) UK [www.tsiinc.co.uk](http://www.tsiinc.co.uk)  
Germany [www.tsiinc.de](http://www.tsiinc.de) France [www.tsiinc.fr](http://www.tsiinc.fr)

Manufacturer of TSI®, AirFlow™ Instruments, and Alnor® products.

P/N 2980174 Rev E

Copyright © 2008 by TSI Incorporated



## LIMITATION OF WARRANTY AND LIABILITY

### Copyright©

TSI Incorporated / 2009-2010 / All rights reserved.

### LIMITATION OF WARRANTY AND LIABILITY (effective July 2000)

Seller warrants the goods sold hereunder, under normal use and service as described in the operator's manual, shall be free from defects in workmanship and material for twenty-four (24) months, or the length of time specified in the operator's manual, from the date of shipment to the customer. This warranty period is inclusive of any statutory warranty. This limited warranty is subject to the following exclusions:

- a. Hot-wire or hot-film sensors used with research anemometers, and certain other components when indicated in specifications, are warranted for 90 days from the date of shipment.
- b. Parts repaired or replaced as a result of repair services are warranted to be free from defects in workmanship and material, under normal use, for 90 days from the date of shipment.
- c. Seller does not provide any warranty on finished goods manufactured by others or on any fuses, batteries or other consumable materials. Only the original manufacturer's warranty applies.
- d. Unless specifically authorized in a separate writing by Seller, Seller makes no warranty with respect to, and shall have no liability in connection with, goods which are incorporated into other products or equipment, or which are modified by any person other than Seller.

The foregoing is IN LIEU OF all other warranties and is subject to the LIMITATIONS stated herein. **NO OTHER EXPRESS OR IMPLIED WARRANTY OF FITNESS FOR PARTICULAR PURPOSE OR MERCHANTABILITY IS MADE.**

TO THE EXTENT PERMITTED BY LAW, THE EXCLUSIVE REMEDY OF THE USER OR BUYER, AND THE LIMIT OF SELLER'S LIABILITY FOR ANY AND ALL LOSSES, INJURIES, OR DAMAGES CONCERNING THE GOODS (INCLUDING CLAIMS BASED ON CONTRACT, NEGLIGENCE, TORT, STRICT LIABILITY OR OTHERWISE) SHALL BE THE RETURN OF GOODS TO SELLER AND THE REFUND OF THE PURCHASE PRICE, OR, AT THE OPTION OF SELLER, THE REPAIR OR REPLACEMENT OF THE GOODS. IN NO EVENT SHALL SELLER BE LIABLE FOR ANY SPECIAL, CONSEQUENTIAL OR INCIDENTAL DAMAGES. SELLER SHALL NOT BE RESPONSIBLE FOR INSTALLATION, DISMANTLING OR REINSTALLATION COSTS OR CHARGES. No Action, regardless of form, may be brought against Seller more than 12 months after a cause of action has accrued. The goods returned under warranty to Seller's factory shall be at Buyer's risk of loss, and will be returned, if at all, at Seller's risk of loss.

Buyer and all users are deemed to have accepted this LIMITATION OF WARRANTY AND LIABILITY, which contains the complete and exclusive limited warranty of Seller. This LIMITATION OF WARRANTY AND LIABILITY may not be amended, modified or its terms waived, except by writing signed by an Officer of Seller.

### Service Policy

Knowing that inoperative or defective instruments are as detrimental to TSI as they are to our customers, our service policy is designed to give prompt attention to any problems. If any malfunction is discovered, please contact your nearest sales office or representative, or call Customer Service department at (800) 874-2811 (USA), (1) 651-490-2811 (International), or +44 (0) 149 4 459200 (UK).

### Trademarks

Alnor, TSI, Balometer, and the TSI logo are registered trademark of TSI Incorporated.



# CONTENTS

<b>About This Manual</b> .....	<b>iii</b>
Caution.....	iii
Technical Assistance—Help! .....	iii
<b>Chapter 1. Introduction</b> .....	<b>5</b>
<b>Chapter 2. Unpacking and Hood Set Up</b> .....	<b>7</b>
Unpacking.....	7
Hood Setup .....	8
Models ABT701, ABT711—2 ft x 2 ft (610 mm x 610 mm) .....	8
Models ABT703, ABT713—16 in x 16 in (406 mm x 406 mm) .....	9
Attaching and Detaching the ABT Meter to the Capture Hood Base .....	10
Power the Meter with Batteries .....	11
Meter Zero Adjustment.....	11
Detachable Handle.....	12
<b>Chapter 3. Getting Started</b> .....	<b>13</b>
Analog Meter Operation .....	13
Hold Switch .....	14
Step-By-Step Example Operation .....	15
<b>Chapter 4. Changing Flow Hoods</b> .....	<b>17</b>
Hood Assembly .....	17
Alternate Hood Installation .....	17
<b>Chapter 5. Maintenance and Troubleshooting</b> .....	<b>23</b>
Fabric Hood.....	23
Analog Meter.....	23
Manifold.....	23
Cases.....	23
Calibration.....	23
<b>Appendix A. Actual vs. Standard Air Flow Measurements</b> .....	<b>25</b>
<b>Specifications*</b> .....	<b>27</b>




# About This Manual

This manual explains how to set up, operate and maintain the Alnor<sup>®</sup> ABT Balometer<sup>®</sup> Capture Hood Models ABT701, ABT703, ABT711, and ABT713. Be sure to read it thoroughly before using the instrument.

## Caution

---

<b>CAUTION</b>	
	WHILE USING THE BALOMETER <sup>®</sup> AIR BALANCING INSTRUMENT TO TEST AIR FLOW IN DUCTS, YOU MAY COME INTO CONTACT WITH OR BE EXPOSED TO DUST, POLLEN, MOLD, FUNGUS, OR OTHER AIRBORNE CONTAMINANTS. IF YOU ARE OR MAY BE SENSITIVE TO DUST, POLLEN, MOLD, FUNGUS, OR OTHER AIRBORNE CONTAMINANTS, <b>ALWAYS</b> USE AN APPROPRIATE MASK OR RESPIRATOR WHILE EMPLOYING THE BALOMETER <sup>®</sup> AIR BALANCING INSTRUMENT.

## Technical Assistance—Help!

---

For technical assistance or questions about the instrument, or if the instrument needs repair or recalibration, call Customer Service at (800) 874-2811 (USA), (1) 651-490-2811 (International), or +44 (0) 149 4 459200 (UK). Product application notes are available to provide more information on the product. These application notes, as well as other related material, can be obtained by calling Customer Service or by visiting the web site at [www.alnor.com](http://www.alnor.com) or [www.airflowinstruments.co.uk](http://www.airflowinstruments.co.uk).





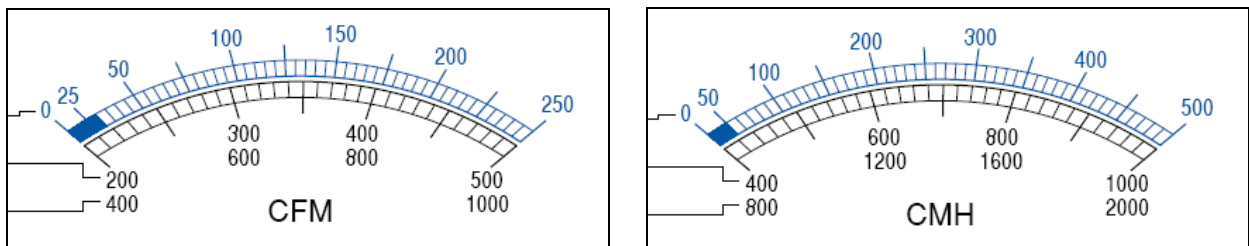
# Chapter 1. Introduction

The Alnor® Analog Balancing Tool (ABT) Balometer® capture hood Models ABT701, ABT703, ABT711, and ABT713 are productivity instruments designed to quickly measure the air flow directly from supply diffusers and return/exhaust grilles mounted in a ceiling, wall or floor with equal accuracy. The ABT consists of:

- fabric hood
- hood frame
- support rods
- molded plastic base (which contains the meter and a flow sensing manifold).

Air flowing through the hood is measured by a hot-film sensor located in the central hub of the flow sensing manifold. The twenty-four pairs of flow sensing ports in the manifold are strategically located so that the ABT provides a high degree of measurement accuracy, even in non-uniform flow conditions.

The ABT Models are temperature-compensated to display a standard flow rate in CFM (ft<sup>3</sup>/min.) or CMH (m<sup>3</sup>/hr) depending on the model ordered. Standard flow rate is defined as the volumetric flow rate at standard conditions of 70°F (21.1°C) and 29.92 inHg (760 mm Hg) barometric pressure.



For increased flexibility, additional hood sizes are available to fit interchangeably on the instrument base. These additional hoods are used with frame pieces which must be assembled by the user. Instructions for assembly can be found in this manual (see Chapter 2, “[Hood Setup](#)” and Chapter 4, “[Hood Assembly](#)”) for the following sizes:

- 1 ft × 4 ft (305 mm × 1220 mm)
- 2 ft × 4 ft (610 mm × 1220 mm)
- 3 ft × 3 ft (915 mm × 915 mm)
- 1 ft × 5 ft (305 mm × 1525 mm)
- 16 in × 16 in (406 mm × 406 mm).



## CAUTION

The ABT Balometer® capture hood is **not** designed for gas mixtures other than air. Any use with corrosive or other dangerous or explosive gas mixtures is not recommended, and is at the user's risk.



### CAUTION

WHILE USING THE BALOMETER<sup>®</sup> AIR BALANCING INSTRUMENT TO TEST AIR FLOW IN DUCTS, YOU MAY COME INTO CONTACT WITH OR BE EXPOSED TO DUST, POLLEN, MOLD, FUNGUS, OR OTHER AIRBORNE CONTAMINANTS. IF YOU ARE OR MAY BE SENSITIVE TO DUST, POLLEN, MOLD, FUNGUS, OR OTHER AIRBORNE CONTAMINANTS, **ALWAYS** USE AN APPROPRIATE MASK OR RESPIRATOR WHILE EMPLOYING THE BALOMETER<sup>®</sup> AIR BALANCING INSTRUMENT.

## Chapter 2. Unpacking and Hood Set Up

This chapter describes unpacking and setting up (preparing) the ABT Balometer<sup>®</sup> capture hood for use.

### Unpacking

As you unpack the instrument and accessories, check the components against your packing list. If any parts are missing or damaged, notify us immediately. Table 1 lists available standard and optional components.

The ABT Models ship with the hood and frame attached to the instrument base and must be removed from the case as a set before the instrument base can be lifted out. Caution must be exercised to assure that the pieces do not separate, since dropping the instrument may damage the instrument.

**Table 1: List of Standard and Optional Components**

Item	Part No.
Model ABT701—30 to 1000 CFM with 2 ft × 2 ft (610 mm × 610 mm) hood	ABT701
Model ABT711—50 to 2000 CMH with 2 ft × 2 ft (610 mm × 610 mm) hood	ABT711
Model ABT703—30 to 1000 CFM with 16 in × 16 in (406 mm × 406 mm) hood	ABT703
Model ABT713—50 to 2000 CMH with 16 in × 16 in (406 mm × 406 mm) hood	ABT713
Wheeled Carrying case	1319379
AA-size alkaline battery, four required	1208013
Operation and Service Manual	6002462
Center handle	534593173
1 ft × 4 ft (305 mm × 1220 mm) and 2 ft × 4 ft (610 mm × 1220 mm) fabric hood and frame kit	801206
1 ft × 5 ft (305 mm × 1525 mm) and 3 ft × 3 ft (915 mm × 915 mm) fabric hood and frame kit	801207
1 ft × 4 ft (305 mm × 1220 mm) fabric hood and frame kit	801200
2 ft × 4 ft (610 mm × 1220 mm) fabric hood and frame kit	801201
1 ft × 5 ft (305 mm × 1525 mm) fabric hood and frame kit	801202
2 ft × 2 ft (610 mm × 610 mm) fabric hood and frame kit	801097
16 in × 16 in (406 mm × 406 mm) hood and frame kit	801209

Please register your ABT Balometer<sup>®</sup> capture hood online at <http://register.tsi.com>. Registering your product will allow us to inform you of product updates.

## Hood Setup

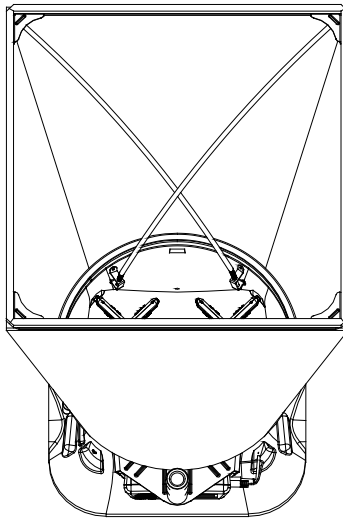
---

The ABT Balometer<sup>®</sup> capture hood is shipped from the factory partially assembled with the 2 ft × 2 ft (610 mm × 610 mm) or 16 in × 16 in (406 mm × 406 mm) nylon hood attached to the base. If you wish to use another hood size, see [Chapter 4. Changing Flow Hoods](#).

### Models ABT701, ABT711—2 ft x 2 ft (610 mm x 610 mm)

To complete the assembly of the 2 ft × 2 ft (610 mm × 610 mm) hood, follow these steps:

1. Place the base of the capture hood on the floor.
2. Lift the top of the fabric. Insert one end of a support pole into its pole mount in the base. There is a cup in each corner of the frame to accept the other end of each support pole.
3. Grasp the support pole. Bend the pole slightly to insert the top end of the pole into the support pole cup located in the opposite corner of the fabric frame. The poles are connected to the frame corners in a crisscross fashion as shown in Figure 1.



**Figure 1**

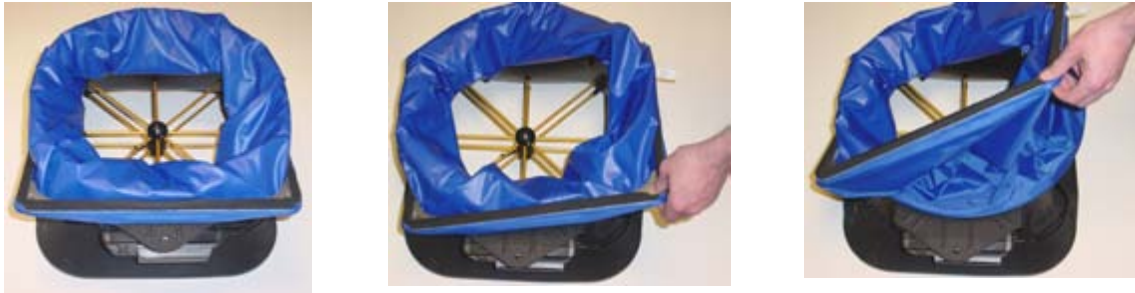
Installing a Support Pole on a 2 ft × 2 ft (610 mm × 610 mm) Hood

4. Insert the second support pole into the pole mount on the opposite side of the base.
5. Repeat step 3 for the second support pole.
6. Repeat steps 4 and 5 for the remaining two support poles.

## Models ABT703, ABT713—16 in × 16 in (406 mm × 406 mm)

To complete the assembly of the 16 in × 16 in (406 mm × 406 mm) hood, follow these steps:

1. Place the base of the capture hood on the floor.
2. For storage purposes, the 16 in × 16 in (406 mm × 406 mm) frame sits around the top lip of the base. To assemble, lift one of the front hood corners on an angle to remove the frame from the stowed position. See Figure 2.



**Figure 2**

Removing the 16 in x 16 in (406 mm x 406 mm) Hood from Stowed Position

3. Insert one end of a support pole into its pole mount in the base. There are two cups on the frame to accept the other end of each support pole.
4. Grasp the support pole. Bend the pole slightly to insert the top end of the pole into the support pole cup located on the opposite side of the fabric frame. The poles are connected to the frame corners in a crisscross fashion as shown in Figure 3.



**Figure 3**

Installing the Support Poles on a 16 in × 16 in (406 mm × 406 mm) Hood

5. Insert the second support pole into the pole mount on the opposite side of the base.
6. Repeat step 4 for the second support pole.
7. Repeat steps 5 and 6 for the remaining two support poles.

## **Attaching and Detaching the ABT Meter to the Capture Hood Base**

---

1. Tilt the meter forward and align the tabs in the base of the meter with the two matching slots in the bottom of the recessed area at the front of the base (see Figure 4).
2. When the tabs are engaged in the slots, press firmly on the face of the meter above the display until the tab in the top center of the meter “clicks” into the bent metal retaining clip in the base.
3. Attach the sensor cable and the hold switch cable to the right side of the meter.
4. To remove the meter from the base, first disconnect the sensor cable and the hold switch cable, then press upward on the metal retaining clip to release the meter from the base.



**Figure 4**  
Attaching the Meter to the Capture Hood Base

## Power the Meter with Batteries

---

The ABT requires four AA-size alkaline batteries to operate. For your convenience, four alkaline batteries are included with the ABT.

To install batteries:

1. Turn the unit off and locate the battery cover on the back of the meter (see Figure 5).
2. Press down on the compartment cover and slide it down (the cover slides off).
3. Remove the battery holder by pulling up on the bottom (to loosen it) and then remove the battery holder.
4. Remove the old batteries and replace with fresh batteries. Make certain batteries are correctly oriented.
5. Reinstall the battery holder and replace the compartment cover.

### Note

Make sure the battery holder is oriented so that its terminals make contact with the spring contacts in the battery compartment.

### CAUTION

Due to the danger of battery leakage, remove batteries from the battery compartment before storage. **Never** mix battery types.



**Figure 5**  
Battery Cover Removal

## Meter Zero Adjustment

---

Check to see that the pointer of the Meter is at zero each time the meter is put into service. The zero adjust screw enables the user to align the pointer to the zero mark on the scale. With the meter turned off, use a screwdriver to bring the pointer to zero. It should read zero regardless of how the Balometer<sup>®</sup> capture hood is held (see Figure 7).

## Detachable Handle

---

For maximum flexibility in using or carrying the Balometer<sup>®</sup> capture hood, install the detachable handle (see Figure 6). Simply screw it “hand tight” into its mating thread on the support plate above the meter.

<b>Note</b>
Check the tightness of this handle each time before use to ensure it doesn't loosen while the instrument is being used to take readings or being carried from place to place.



**Figure 6**  
Center Handle



# Chapter 3. Getting Started

This section provides information to help you quickly become familiar with the ABT Model functions.

## Analog Meter Operation

The analog meter lets you initiate functions and view flow measurements. Prior to operating the instrument, read this section to more fully understand what each of the keys do (see Figure 7).



**Figure 7**  
Analog Meter Components

I/O Key	<p>Press and release to turn the ABT meter on. Press and hold for 2 seconds to turn the ABT meter off.</p> <p>During the power-up sequence, all the LEDs will be briefly illuminated and the indicator needle will deflect to full scale and then back to zero. Once the indicator is back to zero, the instrument is ready to take measurements.</p> <p><b>Note:</b> If the indicator needle does not deflect to full-scale position during the power-up sequence, the meter may be damaged and may not read flow accurately. See the "<a href="#">Maintenance and Troubleshooting</a>" section of this manual for further details.</p>
Supply and Return Flow ( ) Keys	<p>Press to switch between supply (▼) flow and return (▲) flow measurement.</p>
Range Selection	<p>Press to switch between the low, medium, and high measurement range.</p> <p><b>Note:</b> If unsure of the flow, set the ABT to the highest range first.</p>

Battery indicator	<p>The battery indicator remains OFF when battery levels are in the normal operating range.</p> <p>When the batteries are becoming depleted, the battery indicator will flash, indicating that the batteries should be changed soon.</p> <p>When the batteries are fully depleted, the battery indicator will remain constant ON, and after a few minutes the ABT meter will automatically power-off. At this stage, the batteries must be replaced to resume normal operation.</p>
Meter zero adjust	<p>The zero adjust screw aligns the pointer to the zero mark on the scale. With the meter turned off, use a screwdriver to bring the pointer to zero in the position it will be used in with no flow.</p>
Sensor Cable	<p>The sensor cable must be plugged into the ABT meter to perform flow measurement. If the sensor cable is not plugged in or is loose, the Supply and Return indicator LEDs will flash to indicate this condition.</p>

## Hold Switch

To “hold” a particular value on the display, momentarily press and release the red trigger button located on the left side of the base (see Figure 8). To restart the measurements from a “held” value, simply press and release the red trigger button again.

### Note

While the reading is being “held”, the LED corresponding to the currently selected range on the range selector indicator will be blinking signifying the hold function is active.



**Figure 8**  
Red Hold Switch Location

## Step-By-Step Example Operation

---

If the instrument has been stored at a temperature below 68°F (20°C) or above 86°F (30°C), it should be allowed to stabilize at room conditions (between 68°F and 86°F) in order to achieve specified accuracy.

1. Assemble the Balometer<sup>®</sup> capture hood as described in Chapter 2, “[Unpacking and Hood Set Up](#),” of this manual.
2. With the meter turned off, check the meter for zero adjustment by placing the instrument away from any air flow and verify that the meter reads zero. If necessary, use a screwdriver to adjust the zero screw so that the pointer reads zero. Although the meter will typically read zero regardless of how the unit is held, it is best to zero the meter in the position in which it will be used.
3. Turn the meter on by pressing the **I/O** key. During the power up sequence, all the LEDs will be illuminated and the indicator needle will peg to full scale and then return to zero. The instrument is now ready for use.
4. Select supply or return mode and set the range to the highest scale. This technique is to ensure the meter will not be damaged by an over range condition when flow is unknown.
5. Place the Balometer<sup>®</sup> capture hood into contact with the perimeter of the diffuser or grill to be measured. To assure maximum accuracy, the foam gasket along the top of the frame must be firmly in contact with the surface all around the opening.
6. If the reading is found to be below the full scale of the next lower scale, the range can be switched to the next lower scale.



# Chapter 4. Changing Flow Hoods

This chapter identifies the flow hood parts and gives instructions for assembling the flow hood.

## Hood Assembly

---

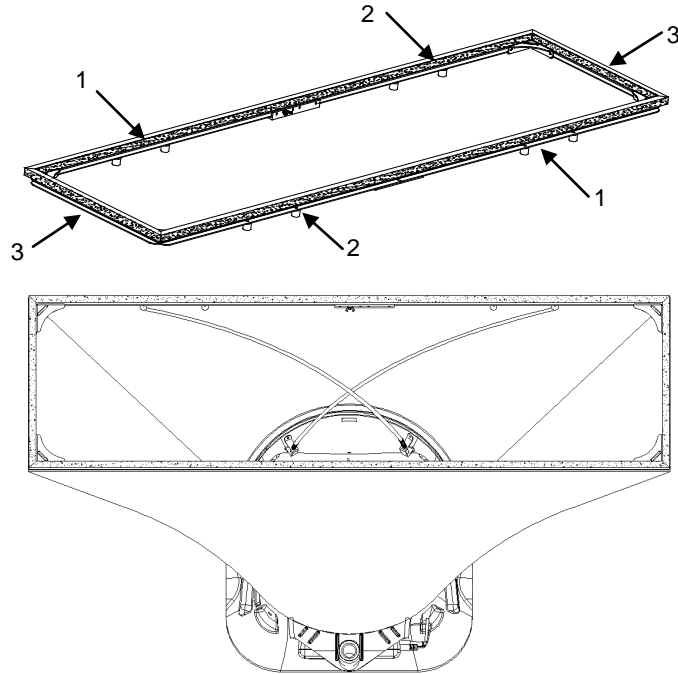
Four other hood sizes are available from TSI and can be purchased separately. Available hood sizes are identified by the dimensions of the frame structure at the top of the hood and include 2 ft × 4 ft (610 mm × 1220 mm), 1 ft × 4 ft (305 mm × 1220 mm), 1 ft × 5 ft (305 mm × 1525 mm) and 3 ft × 3 ft (915 mm × 915 mm).

To change hood sizes, first remove the hood currently attached to the base. To remove the attached hood:

1. Unlatch the cinch belt where the fabric is attached to the base.
2. Remove the fabric from its frame structure by pulling the shock cord out of the aluminum frame.
3. Fold up the fabric you just removed so that it can fit into one of the accessory pockets inside the carrying case. It is a good idea to fold the fabric so that the tag identifying its size remains visible for future reference.

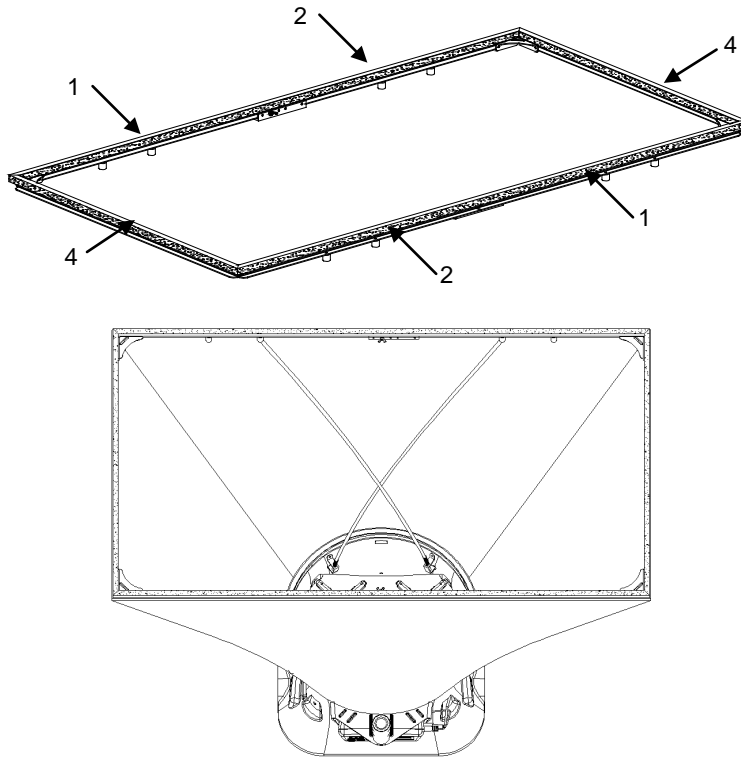
## Alternate Hood Installation

Refer to Figure 9 through Figure 14 to determine the frame channels needed to assemble any of the standard sized frames. Select the pieces required for the frame size desired and assemble with the aid of the appropriate figure. Each channel is labeled with its number for easy identification. Several sections (numbers 1, 3, and 4) consist of a straight channel portion (each a different length) and a corner piece. This corner piece has an eyelet and slot arrangement which mates with a similar eyelet and slot at the end of the straight portion of the channel pieces (see Figure 9). These pieces can be slid together and are self locking by means of a retention spring. The arrangement forms a rugged frame which is additionally strengthened when the hood is attached.



**Figure 9**

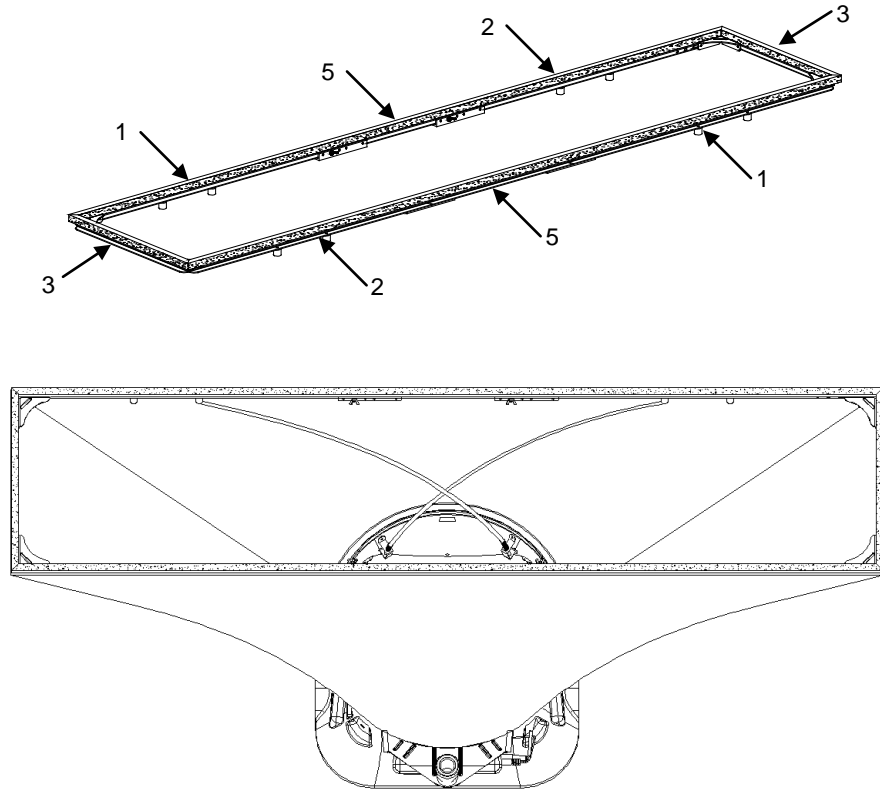
1 ft × 4 ft (305 mm × 1220 mm) hood and frame. The support poles always cross as pairs at the front and back of the fabric hood. For the 1 ft × 4 ft (305 mm × 1220 mm), the support poles are inserted into the outside ferrule locations.



**Figure 10**

2 ft × 4 ft (610 mm × 1220 mm) hood and frame. The support poles always cross as pairs at the front and back of the fabric hood. For the 2 ft × 4 ft (610 mm × 1220 mm), the support poles are inserted into the inside ferrule locations.

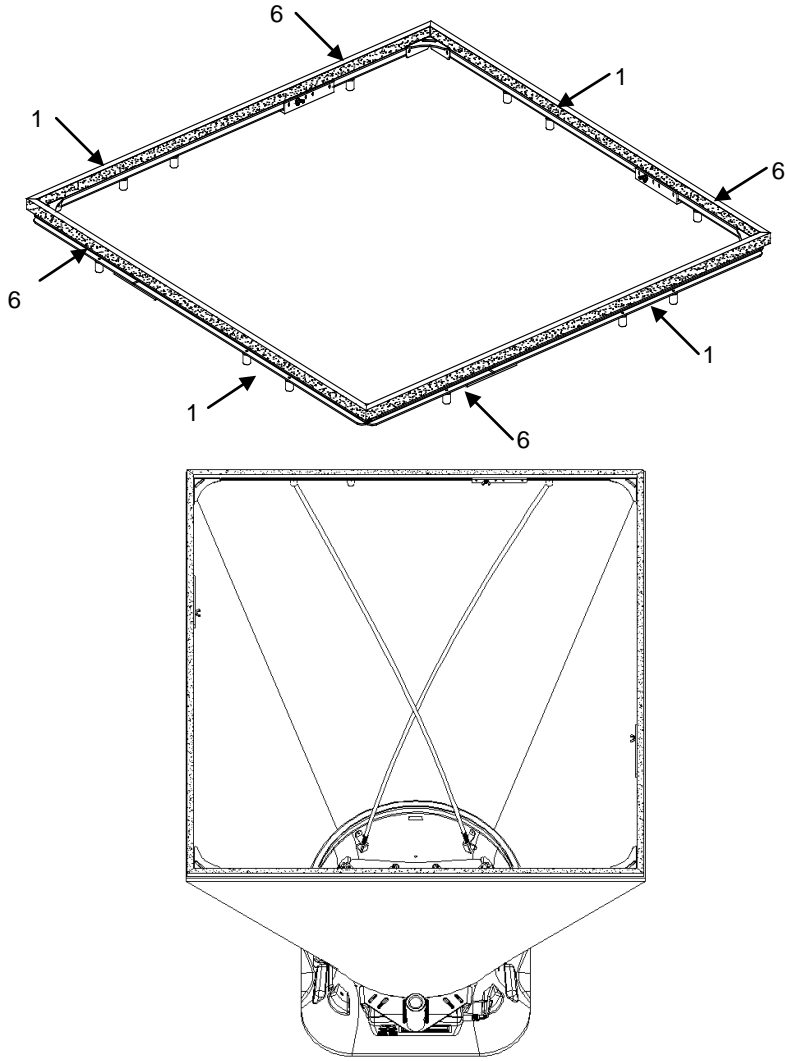
The number 1 and 5 channels also have a wing nut at the straight end which will mate with an angle and studs on the ends of numbers 2, 5 and 6 to form the longer frame sides (see Figure 11).



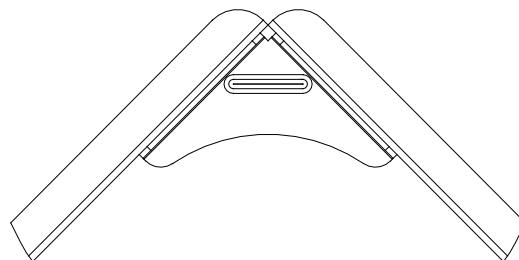
**Figure 11**

1 ft × 5 ft (305 mm × 1525 mm) hood and frame. The support poles always cross as pairs at the front and back of the fabric hood. For the 1 ft × 5 ft (305 mm × 1525 mm), the support poles are inserted into the inside ferrule locations.

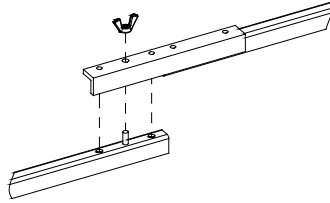




**Figure 12**  
 3 ft × 3 ft (915 mm × 915 mm) hood and frame. The support poles always cross as pairs at the front and back of the fabric hood. For the 3 ft × 3 ft (915 mm × 915 mm), the support poles are inserted into the outside ferrule locations.



**Figure 13**  
 Frame Corner Assembly



**Figure 14**  
Frame Side Coupler Assembly

Each hood is constructed in a trapezoidal shape, sewn together so that one open end forms a round attachment to the base, and the other forms a square or rectangle large enough to fit its matching frame assembly. Around the frame end of the hood, an elastic shock cord has been sewn into the hood. This cord is of a size such that it can be pushed into the open side of the U-shaped channels of the frame.

In general, attach a hood to the frame first, and then to the base unit. By stretching around the frame corners the cord is slightly reduced in diameter and is easier to press into the frame channel.

**Note**

The hood corners should always be aligned with the corners of the base, near the hood support brackets. The base has rivets located in the corners which can be used as a guide for aligning the hood corners.

# Chapter 5. Maintenance and Troubleshooting

The Alnor<sup>®</sup> Analog Balancing Tool Models ABT701/ABT703/ABT711/ABT713 are designed for long-term field use. If used with reasonable care, they should be able to make precise measurements over a long time period. Some of the components can be cleaned periodically. When cleaning the components, please follow the instructions given below.

---

## Fabric Hood

---

The hoods can be washed with mild detergent and cold water. When washing the hood, keep the hood away from objects with sharp corners or sharp edges. Careless cleaning may cause damage.

If the fabric gets ripped it should be replaced or repaired. Duct tape can be placed over the rip on both sides of the fabric for temporary repair.

To replace a damaged fabric or to order a different fabric size, contact your local TSI<sup>®</sup>/Alnor<sup>®</sup> distributor.

---

## Analog Meter

---

The analog meter case, display screen and keys can be cleaned using a damp cloth with mild detergent solution. Do **not** immerse it in water. Wipe the unit dry before use.

---

## Manifold

---

If you observe the flow sensing taps of the manifold becoming clogged with dust or other material, clean them with a damp cloth. The manifold should be kept in place during cleaning. Do **not** apply excessive forces on the grid of the manifold. If any part of the grid is damaged, please contact Customer Service for repair information (see “[Technical Assistance—Help!](#)” earlier in this manual).

---

## Cases

---

If the instrument case or storage case needs cleaning, wipe it off with a soft cloth and isopropyl alcohol or a mild detergent.

---

## Calibration

---

TSI recommends an annual calibration for the instrument. For a nominal fee, we will calibrate the unit and return it to you with a certificate of calibration and NIST traceability. This “annual checkup” assures you of consistently accurate readings. To calibrate the instrument, please ship the complete package that includes the meter, the base, the manifold and any fabrics used. The meter and base are calibrated as a set and must be returned together for calibration. Everything should be packed carefully within the carrying case and then inside a shipping box. The original shipping box is preferred. Before sending your instrument for calibration or repair, obtain a Return Material Authorization (RMA) number by visiting our website at <http://rma.tsi.com> or contacting customer service. When obtaining an RMA number, you will also learn the cost of service or calibration and receive shipping instructions.

Table 2 lists the symptoms, possible causes, and recommended solutions for common problems encountered with the instrument. If your symptom is not listed, or if none of the solutions solves your problem, please contact the factory.

**Table 2:** Troubleshooting the Instrument

Symptom	Possible Causes	Corrective Action
No LEDs light up.	Unit not turned on. Low or dead batteries. Dirty battery contacts. Meter may be damaged and need repair.	Press <b>I/O</b> key. Replace the batteries. Clean the battery contacts. Return to factory for service.
Meter needle does not move with flow stimulus.	Unit not turned on. Low or dead batteries. Dirty battery contacts. Meter is in flow “Hold” condition (if 1 Range LED is also blinking). Meter may be damaged and need repair.	Press <b>I/O</b> key. Replace the batteries. Clean the battery contacts. Press and release the hold button to resume normal flow reading. Return to factory for service.
During power-on sequence, meter needle does not deflect to full-scale position.	Meter needle zero is out of adjustment. Meter may be damaged and need repair.	Verify correct meter needle zero adjustment. Return to factory for service.
1 Range LED is blinking.	Meter is in flow “Hold” condition.	Press and release the hold button to resume normal flow reading.
Supply and Return LEDs blink On and Off.	Sensor cable disconnected from meter. Flow sensor or cabling may be damaged and need repair.	Verify sensor cable is connected. Return to factory for service.
All 3 Range LEDs blink On and Off.	Meter may be damaged and need repair.	Return to factory for service.
Battery indicator is blinking.	Batteries are becoming depleted.	Replace the batteries.
Battery indicator is constant On.	Batteries are fully depleted.	Replace the batteries.
Unit powers On, but automatically turns itself Off shortly thereafter.	Batteries are fully depleted.	Replace the batteries.

# Appendix A. Actual vs. Standard Air Flow Measurements

Thermo-anemometer sensors measure mass air flow velocity which is a measurement of the air mass moving past the sensor and is displayed as standard velocity. Air mass is what gives air its heat holding capacity. Since thermal anemometers measure air mass and display it as standard velocity, many people doing measurements on indoor air are more concerned with standard air velocity.

Standard readings can be converted to actual air velocity to compensate for temperature and barometric pressures. Actual or standard measurements will give the same readings at standard conditions (using a reference of 70°F [21.1°C] and 29.92 in. Hg [101.4 kPa]), but not if pressure or temperature stray from standard conditions.

To calculate actual air velocity, multiply the standard velocity reading indicated by the thermoanemometer by the following density correction factor:

$$\text{Actual Velocity} = (\text{Standard Velocity}) [(460 + T) / (460 + 70)] * 29.92 / P_m$$

*or*

$$\text{Actual Velocity} = (\text{Standard Velocity}) [(273 + T_m) / (273 + 21.1)] * 101.4 / P$$

Where:

T = Ambient temperature in degrees Fahrenheit

P<sub>m</sub> = Ambient pressure in inches of Hg.

T<sub>m</sub> = Ambient temperature in degrees Centigrade

P = Ambient pressure in kPa



# Specifications\*

## Supply and Exhaust Ranges

ABT701/ABT703 30 to 1,000 CFM (ft<sup>3</sup>/min)

ABT711/ABT713 50 to 2,000 CMH (m<sup>3</sup>/hr)

## Accuracy

ABT701/ABT703 ±3% of full scale selected +5 CFM (ft<sup>3</sup>/min)

ABT711/ABT713 ±3% of full scale selected +10 CMH (m<sup>3</sup>/hr)

## Units

CFM (ft<sup>3</sup>/min) Models ABT701 and ABT703

CMH (m<sup>3</sup>/hr) Models ABT711 and ABT713

## Scale Divisions (Supply/Exhaust)

CFM (ft<sup>3</sup>/min)

5 from 30 to 250

10 from 200 to 500

20 from 400 to 1000

CMH (m<sup>3</sup>/hr)

10 from 50 to 500

20 from 400 to 1000

40 from 800 to 2000

## Power Requirements

Four AA-size cells alkaline

## Battery Life (continuous)

200 CFM ( 340 CMH) 29.2 hours

800 CFM (1360 CMH) 21.3 hours

1000 CFM (1700 CMH) 20.4 hours

## Weight with Batteries

7.4 lb (3.4 kg)

## Operating Temperature Range

32 to 140°F (0 to 60°C)

## Storage Temperature Range

-40 to 140°F (-40 to 60°C)

## Model Description

ABT701 30 to 1000 CFM (ft<sup>3</sup>/min) with 2 ft × 2 ft (610 mm × 610 mm) hood

ABT703 30 to 1000 CFM (ft<sup>3</sup>/min) with 16 in × 16 in (406 mm × 406 mm) hood

ABT711 50 to 2000 CMH (m<sup>3</sup>/hr) with 2 ft × 2 ft (610 mm × 610 mm) hood

ABT713 50 to 2000 CMH (m<sup>3</sup>/hr) with 16 in × 16 in (406 mm × 406 mm) hood

## Optional Hood and Frame Kits

801097 2 ft × 2 ft (610 mm × 610 mm)

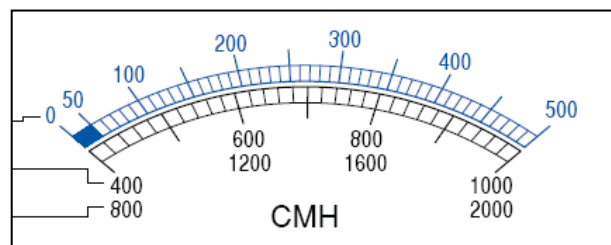
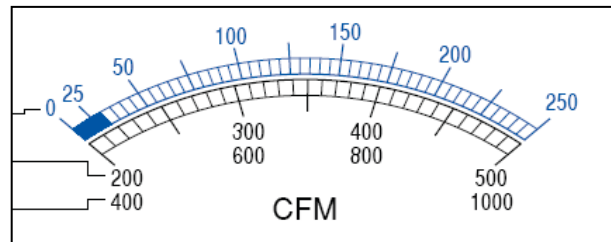
801201 2 ft × 4 ft (610 mm × 1220 mm)

801200 1 ft × 4 ft (305 mm × 1220 mm)

801202 1 ft × 5 ft (305 mm × 1525 mm)

801203 3 ft × 3 ft (915 mm × 915 mm)

801209 16 in × 16 in (406 mm × 406 mm)



\*Specifications are subject to change without notice.

---

Alnor Products, TSI Incorporated – 500 Cardigan Road, Shoreview, MN 55126 U.S.A

USA	Tel: +1 800 874-2811	E-mail: <a href="mailto:customerservice@alnor.com">customerservice@alnor.com</a>	Website: <a href="http://www.tsi.com">www.tsi.com</a>
UK	Tel: +44 149 4 459200	E-mail: <a href="mailto:tsiuk@tsi.com">tsiuk@tsi.com</a>	Website: <a href="http://www.tsiinc.co.uk">www.tsiinc.co.uk</a>
France	Tel: +33 491 11 87 64	E-mail: <a href="mailto:tsifrance@tsi.com">tsifrance@tsi.com</a>	Website: <a href="http://www.tsiinc.fr">www.tsiinc.fr</a>
Germany	Tel: +49 241 523030	E-mail: <a href="mailto:tsigmbh@tsi.com">tsigmbh@tsi.com</a>	Website: <a href="http://www.tsiinc.de">www.tsiinc.de</a>
India	Tel: +91 80 41132470	E-mail: <a href="mailto:tsi-india@tsi.com">tsi-india@tsi.com</a>	
China	Tel: +86 10 8260 1595	E-mail: <a href="mailto:tsibeijing@tsi.com">tsibeijing@tsi.com</a>	
Singapore	Tel: +65 6595 6388	E-mail: <a href="mailto:tsi-singapore@tsi.com">tsi-singapore@tsi.com</a>	



Contact your local Alnor Distributor or visit our website [www.alnor.com](http://www.alnor.com) for more detailed specifications.