

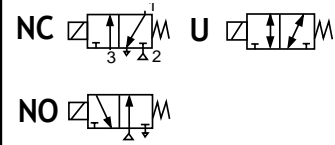

Direct Acting
Sub-Miniature Solenoid Valves
 Brass, Stainless Steel, or Aluminum Bodies
 1/8" NPT



3/2
SERIES
8325
8380

Features

- Smallest poppet valve, suitable for a wide range of inert gasses and liquids.
- Convertible from AC to DC by changing the molded epoxy open frame coil.
- No Minimum Operating Pressure Differential required.
- Ideal valve for OEM applications.
- Group mounted constructions (max. 10 valves) have aluminum bodies and built-in manual operators for air service.
- Mountable in any position.

Construction

Valve Parts in Contact with Fluids		
Body		
Individual Valves	Brass	303 Stainless Steel
Group Mounted	Aluminum	
Seals and Discs	NBR or FKM, as listed	
Core and Plugnut	430F Stainless Steel	
Core Spring	302 Stainless Steel	
Shading Coil	Copper	

Electrical

Standard Coil and Class of Insulation	Watt Rating and Power Consumption				Spare Coil Part No.	
	DC Watts	AC			AC	DC
		Watts	VA Holding	VA Inrush		
F	6.9	6.3	8.8	12.1	400115	400115

Standard Voltages: 24, 120, 240 volts AC, 60 Hz (or 110, 220 volts AC, 50 Hz). 6, 12, 24, 120, 240 volts DC. Must be specified when ordering. Other voltages are available when required.

Solenoid

Standard: Molded epoxy open frame solenoid. Can be converted from AC to DC, or vice versa, by changing the coil.
Optional: 3x DIN 46244 coil; 1/2" threaded conduit hub.
See Optional Feature section for other available options.

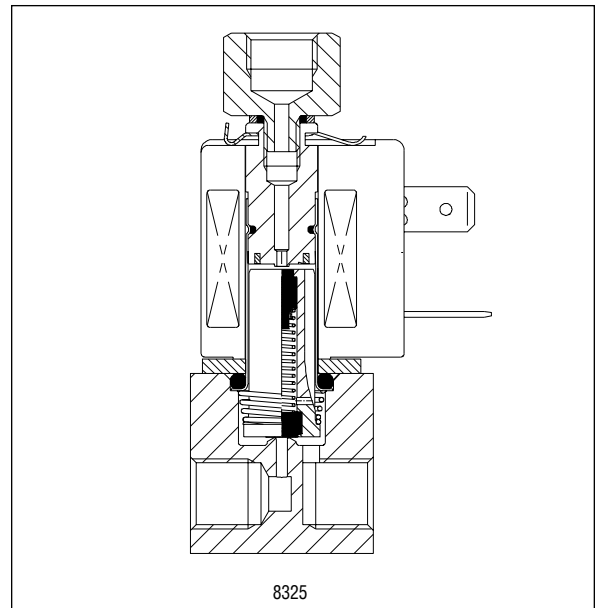
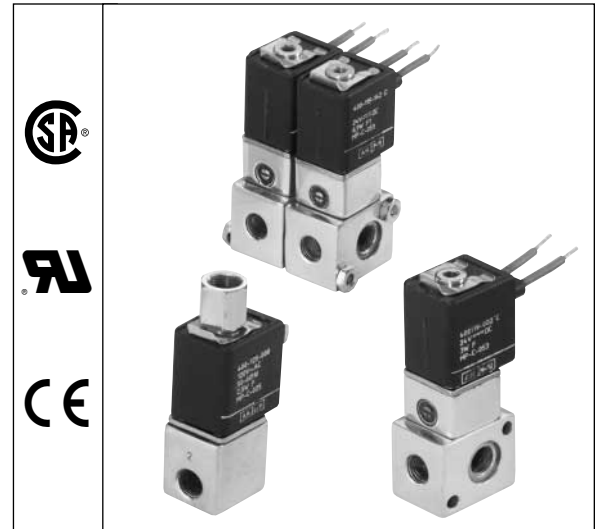

Nominal Ambient Temperature Ranges:

AC: 32°F to 125°F (0°C to 52°C)

DC: 32°F to 77°F (0°C to 25°C)

Refer to Engineering Section for details.

Approvals:

CSA certified. UL recognized components. Meets applicable CE directives.

Refer to Engineering Section for details.

Specifications (English units)

Pipe Size (ins.)	Orifice Size (ins.)	Cv Flow Factor		Operating Pressure Differential (psi) ①						Max. Fluid Temp. °F		Open Frame Solenoid		Watt Rating/Class of Coil Insulation	
				Max. AC			Max. DC					Brass Body	Stainless Steel Body		
		At Port 2	At Port 3	Air-Inert Gas	Water	Light Oil @ 45 SSU	Air-Inert Gas	Water	Light Oil @ 45 SSU	AC	DC	Catalog Number	Catalog Number	AC	DC
UNIVERSAL OPERATION (Pressure at any port), FKM Disc															
1/8	3/64	.05	.07	100	90	90	65	50	40	180	77	U8325B1V	U8325B31V	6.3/F	6.9/F
1/8	1/16	.09	.07	55	55	55	45	30	25	180	77	U8325B2V	U8325B32V	6.3/F	6.9/F
1/8	3/32	.17	.07	30	30	20	15	15	15	180	77	U8325B3V	U8325B33V	6.3/F	6.9/F
1/8	1/8	.23	.07	15	15	15	12	12	12	180	77	U8325B4V	U8325B34V	6.3/F	6.9/F
NORMALLY CLOSED (Closed when de-energized), FKM Disc															
1/8	3/64	.05	.07	150	150	120	150	150	120	180	77	U8325B5V	U8325B35V	6.3/F	6.9/F
1/8	1/16	.09	.07	110	110	75	110	110	75	180	77	U8325B6V	U8325B36V	6.3/F	6.9/F
1/8	3/32	.17	.07	60	60	40	60	60	40	180	77	U8325B7V	U8325B37V	6.3/F	6.9/F
1/8	1/8	.23	.07	40	35	30	40	35	30	180	77	U8325B8V	U8325B38V	6.3/F	6.9/F
NORMALLY OPEN (Open when de-energized), FKM Disc															
1/8	3/64	.05	.07	110	110	110	110	70	50	180	77	U8325B9V	U8325B39V	6.3/F	6.9/F
1/8	1/16	.09	.07	110	110	110	55	35	30	180	77	U8325B10V	U8325B40V	6.3/F	6.9/F
1/8	3/32	.17	.07	110	110	90	25	20	20	180	77	U8325B11V	U8325B41V	6.3/F	6.9/F
1/8	1/8	.23	.07	75	75	65	15	15	15	180	77	U8325B12V	U8325B42V	6.3/F	6.9/F

Pipe Size (ins.)	Orifice Size (ins.)	Cv Flow Factor		Operating Pressure Differential (psi) ①		Max. Fluid Temp. °F		Open Frame Solenoid		Watt Rating/Class of Coil Insulation	
				Max. AC	Max. DC			Operator Only	Sub-Base Construction		
		At Port 2	At Port 3	Air-Inert Gas	Air-Inert Gas	AC	DC	Catalog Number	Catalog Number	AC	DC
GROUP MOUNTING NORMALLY CLOSED (Closed when de-energized), Aluminum Body, NBR Disc											
1/8	3/64	.05	.07	150	150	180	77	U8380B1	8380B2	6.3/F	6.9/F
GROUP MOUNTING UNIVERSAL OPERATION (Pressure at any port), Aluminum Body, NBR Disc											
1/8	3/64	.07	.07	100	100	180	77	-	U8380B3	6.3/F	6.9/F
Notes: ① Ratings are for valves controlling cylinders and diaphragms having dead end flow conditions. When using common pressure to divert flow, valves may be provided to control higher pressure. Consult ASCO for details.											

Specifications (Metric units)

Pipe Size (ins.)	Orifice Size (mm)	Kv Flow Factor (m ³ /h)		Operating Pressure Differential (bar) ①						Max. Fluid Temp. °C		Open Frame Solenoid		Watt Rating/Class of Coil Insulation	
				Max. AC			Max. DC					Brass Body	Stainless Steel Body		
		At Port 2	At Port 3	Air-Inert Gas	Water	Light Oil @ 45 SSU	Air-Inert Gas	Water	Light Oil @ 45 SSU	AC	DC	Catalog Number	Catalog Number	AC	DC
UNIVERSAL OPERATION (Pressure at any port), FKM Disc															
1/8	1.2	.04	.06	7	6	6	4	3	3	81	25	U8325B1V	U8325B31V	6.3/F	6.9/F
1/8	1.6	.08	.06	4	4	4	3	2	2	81	25	U8325B2V	U8325B32V	6.3/F	6.9/F
1/8	2.4	.15	.06	2	2	1	1	1	1	81	25	U8325B3V	U8325B33V	6.3/F	6.9/F
1/8	3.2	.20	.06	1	1	1	1	1	1	81	25	U8325B4V	U8325B34V	6.3/F	6.9/F
NORMALLY CLOSED (Closed when de-energized), FKM Disc															
1/8	1.2	.04	.06	10	10	8	10	10	8	81	25	U8325B5V	U8325B35V	6.3/F	6.9/F
1/8	1.6	.08	.06	8	8	5	8	8	5	81	25	U8325B6V	U8325B36V	6.3/F	6.9/F
1/8	2.4	.15	.06	4	4	3	4	4	3	81	25	U8325B7V	U8325B37V	6.3/F	6.9/F
1/8	3.2	.20	.06	3	2	2	3	2	2	81	25	U8325B8V	U8325B38V	6.3/F	6.9/F
NORMALLY OPEN (Open when de-energized), FKM Disc															
1/8	1.2	.04	.06	8	8	8	8	5	3	81	25	U8325B9V	U8325B39V	6.3/F	6.9/F
1/8	1.6	.08	.06	8	8	8	4	2	2	81	25	U8325B10V	U8325B40V	6.3/F	6.9/F
1/8	2.4	.15	.06	8	8	6	2	1	1	81	25	U8325B11V	U8325B41V	6.3/F	6.9/F
1/8	3.2	.20	.06	5	5	4	1	1	1	81	25	U8325B12V	U8325B42V	6.3/F	6.9/F

Pipe Size (ins.)	Orifice Size (mm)	Kv Flow Factor (m ³ /h)		Operating Pressure Differential (bar) ①		Max. Fluid Temp. °C		Open Frame Solenoid		Watt Rating/Class of Coil Insulation	
				Max. AC	Max. DC			Operator Only	Sub-Base Construction		
		At Port 2	At Port 3	Air-Inert Gas	Air-Inert Gas	AC	DC	Catalog Number	Catalog Number	AC	DC
GROUP MOUNTING NORMALLY CLOSED (Closed when de-energized), Aluminum Body, NBR Disc											
1/8	1.2	.04	.06	10	10	81	25	U8380B1	8380B2	6.3/F	6.9/F
GROUP MOUNTING UNIVERSAL OPERATION (Pressure at any port), Aluminum body, NBR Disc											
1/8	1.2	.04	.06	7	7	81	25	-	U8380B3	6.3/F	6.9/F
Notes: ① Ratings are for valves controlling cylinders and diaphragms having dead end flow conditions. When using common pressure to divert flow, valves may be provided to control higher pressure. Consult ASCO for details.											

Dimensions: inches (mm)

SERIES 8325

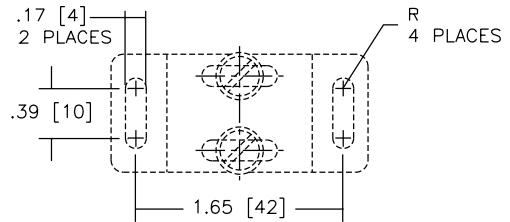
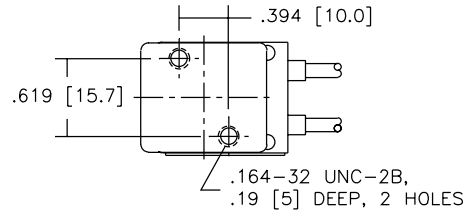
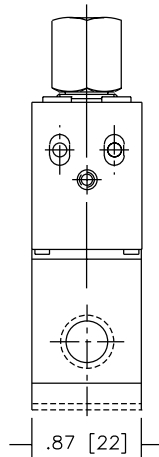
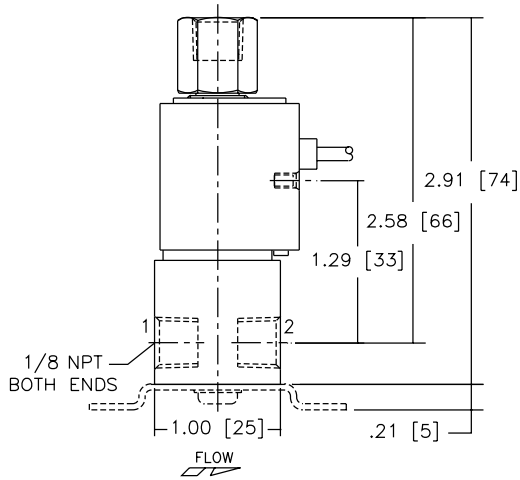

OPTIONAL MOUNTING BRACKET

Flow Diagrams

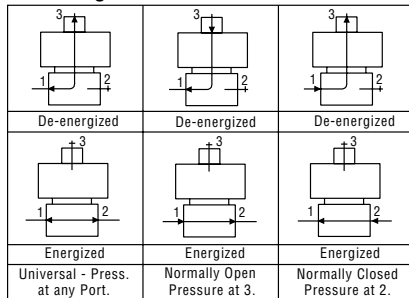

SERIES 8380

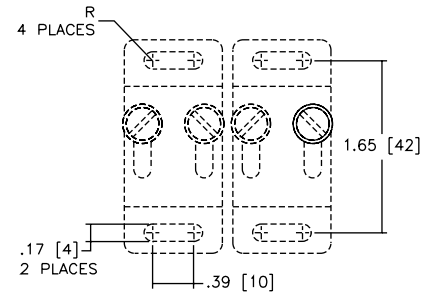
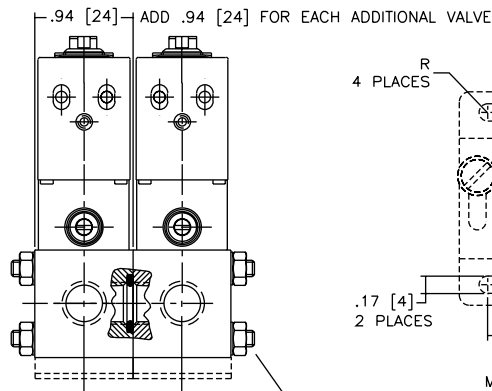
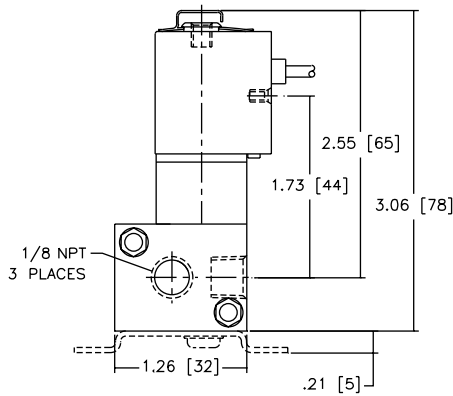

TIE ROD TO BE PROVIDED BY CUSTOMER

Flow Diagrams

