

Hydraulic pressure balance Model CPB5800



WIKA data sheet CT 31.11

Applications

- Primary standard for calibrating the pressure scale in a hydraulic range up to 1,400 bar
- Reference instrument for factory and calibration laboratories for the testing, adjustment and calibration of pressure measuring instruments
- Complete, stand-alone system, also suitable for on-site use

Special features

- Total measurement uncertainty to 0.006 % of reading
- Extremely flexible instrument with a wide range of single and dual-range piston-cylinder systems
- Dual-range piston-cylinder systems with fully automated changing between ranges
- Factory calibration includes traceability to national standards, as standard, with UKAS calibration possible as an option
- Fast and safe replacement of the piston-cylinder system via patented ConTect quick-release system as an option

Description

Proven primary standard

Pressure balances (dead-weight testers) are the most accurate instruments available on the market for the calibration of electronic or mechanical pressure measuring instruments. The direct measurement of the pressure ($p = F/A$), as well as the use of high-quality materials enable a very small measurement uncertainty, in conjunction with an excellent long-term stability.

The pressure balance (dead-weight tester) has therefore been used for years in factory and calibration laboratories in industry, national institutes and research laboratories.

Stand-alone operation

Due to its integrated pressure generation and the pure mechanical measuring principle, the model CPB5800 is ideal for on-site use for maintenance and service.



Hydraulic pressure balance model CPB5800

Basic principle

Pressure is defined as the quotient of force and area. The core component of the CPB5800 is therefore a very precisely-manufactured piston-cylinder system, which is loaded with masses in order to generate the individual test points.

The masses applied are proportional to the target pressure and this is achieved through optimally graduated masses. As standard, these masses are manufactured to the standard gravity (9.80665 m/s^2), though they can be adjusted to a specific location and also UKAS calibrated.

The instrument base, model CPB5800

Easy operation

In the stable instrument base, the integrated priming pump and the 250 ml tank enable large test volumes to be easily filled and pressurised. For further pressure increases and fine adjustment, a very precisely-controllable spindle pump is fitted, which only runs within the pump body.

As soon as the measuring system reaches equilibrium, there is a balance of forces between the pressure and the mass load applied. The excellent quality of the system ensures that this pressure remains stable over several minutes, so that the pressure value for comparative measurements can be read without any problems, or also so that more complex adjustments can be carried out on the item under test.

High-performance instrument range

The CPB5800 instrument base is available in 2 variants:

- Standard hydraulic base
 - up to max. 1,200 bar / 16,000 psi
 - with integrated pressure generation through priming pump and spindle pump
 - Standard pressure transmission medium: mineral oil, optional: Sebacate oil, brake fluid, Skydrol or Fomblin oil
- Hydraulic high-pressure base
 - up to max. 1,400 bar / 20,000 psi
 - with integrated pressure generation through priming pump and spindle pump
 - Pressure transmission medium: mineral oil or Sebacate oil

As standard, both instrument bases are fitted with a connection for the model CPS5800 piston-cylinder system with G 3/4 male thread.

As an option a M30 x 2 female thread for optional CPS5000 piston-cylinder systems is available.

With the 1,200 bar instrument base, the patented ConTect quick-release mechanism is available as an option. This enables the piston-cylinder system to be changed quickly and safely without any tools.

The connection of the test item is made without tools using a quick-connection. Via the freely-rotating knurled nut, the test item can be oriented as required. As standard, a threaded insert with a G 1/2 female thread is provided. Other threaded inserts are available to connect the most common pressure measuring instruments.

Standard connection piston-cylinder system

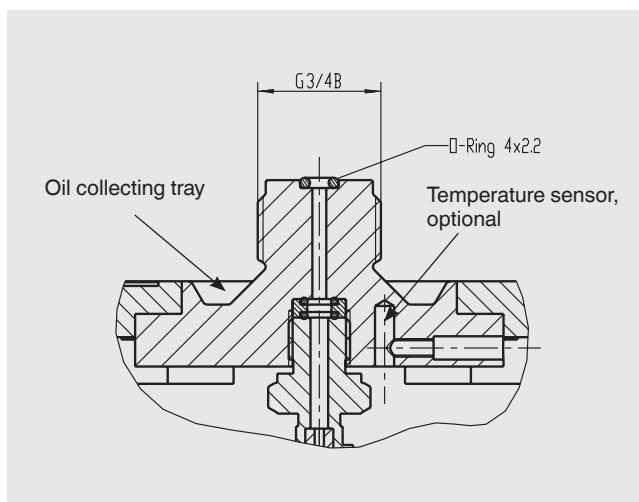

Test item connection

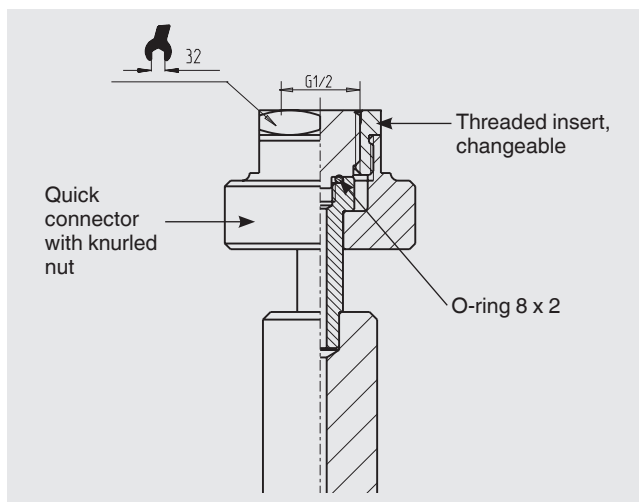

The piston-cylinder system, model CPS5800

The CPS5800 piston-cylinder systems are available in two fundamentally different designs, depending on measuring range.

- Single-range piston-cylinder system (for measuring ranges 120 bar and 300 bar)
- Dual-range piston-cylinder system (for measuring ranges 700 bar, 1,200 bar and 1,400 bar)

High accuracy over a wide measuring range

The dual-range piston-cylinder system offers two measuring ranges in one housing with automatic measuring range switching from low-pressure to high-pressure pistons. This provides the user with an extremely flexible measuring instrument that can cover a wide measuring range with high accuracy, with only one piston-cylinder unit and one mass set. Additionally two test points can automatically be achieved by the operator loading masses once.

The piston and cylinder are manufactured from hardened steel and tungsten carbide, respectively. This pairing of materials has very low pressure and temperature coefficients of expansion, which results in a very good linearity for the cross-sectional area and a very high accuracy.

Piston and cylinder are very well protected, against contact, impacts or contamination from outside, in a solid stainless-steel/hardened tool steel housing. At the same time, overpressure protection is integrated, which prevents the piston from being forced out vertically and avoids damage to the piston-cylinder system in the event of mass removal under pressure.

The masses are stacked directly onto the piston-cylinder shaft. This makes it easier for the operator to place the masses on and thus enables a lower start value.

The overall design of the piston-cylinder unit and the very precise manufacturing of both the piston and the cylinder, ensure exceptionally low friction force, which results in excellent operating characteristics with long free-rotation time and low sink rates. Thus a high long-term stability is ensured. Therefore the recommended recalibration interval is two to five years depending on the conditions of usage.

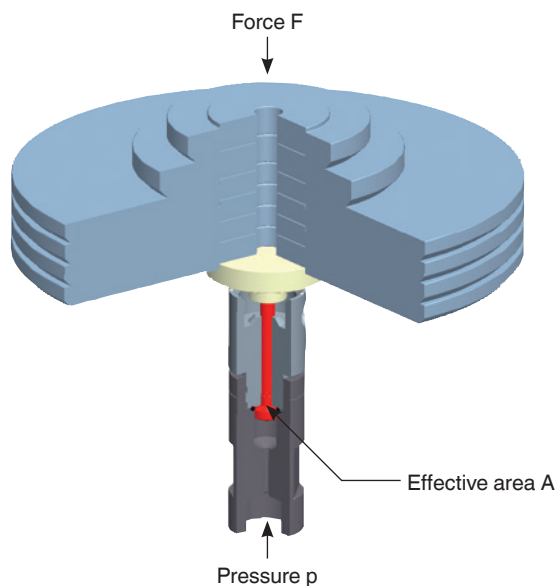

Single-range piston-cylinder system, model CPS5800

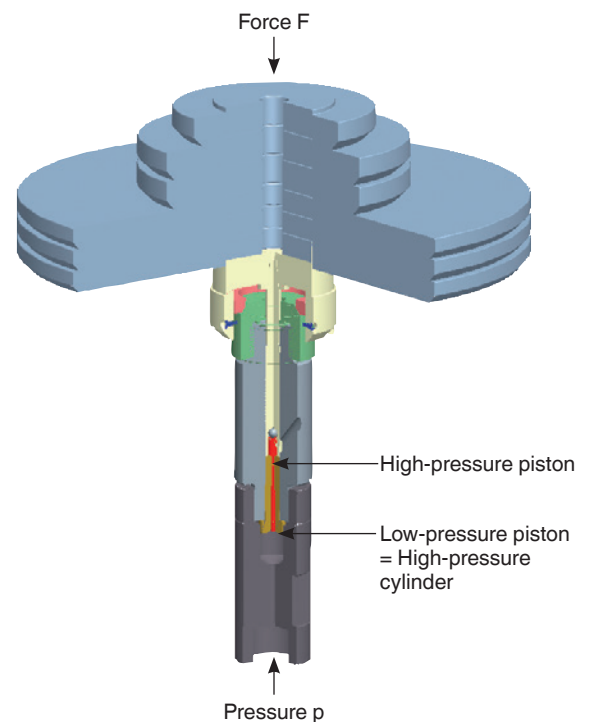

Dual-range piston-cylinder system, model CPS5800

As an option the model CPS5000 hydraulic piston-cylinder systems are available. For detailed specifications see data sheet CT 31.01.

The mass set, model CPM5800

The standard mass set is supplied in a wooden case with a foam insert. This includes the masses listed in the tables of masses below, made from non-magnetic stainless steel, and optimised for everyday use.

For finer increments and for a higher resolution, as an option, the standard mass sets can be extended by a set of fine increment masses.

If even smaller intermediate values need to be generated, using one set of class M1 or F1 trim masses from the accessories is recommended.



Mass set model CPM5800

As an option for the CPS5000 piston-cylinder systems CPM5000 mass sets are available. For detailed specifications see data sheet CT 31.01.

Tables of masses

The following tables show, for the respective measuring range, the number of masses within a set of masses, with their resulting nominal pressures.

Should you not operate the instrument under reference conditions (ambient temperature 20 °C, air pressure 1,013 mbar, relative humidity 40 %), the relevant corrections must be made for example with the CPU6000 CalibratorUnit, see page 11.

The masses are manufactured, as standard, to the standard gravity (9.80665 m/s²) although they can be adjusted for any particular location.

The mass sets can be manufactured for the following different pressure units, bar, kg/cm², kPa, MPa or psi and can be used with the same piston-cylinder system.

Measuring range [bar] or [kg/cm ²]	Single-piston measuring ranges				Dual-piston measuring ranges								
	1 ... 120		2 ... 300		1 ... 700		1 ... 1,200		1 ... 1,400				
	Quantity	Nominal pressure per piece	Quantity	Nominal pressure per piece	Quantity	Nominal pressure per piece	Quantity	Nominal pressure per piece	Quantity	Nominal pressure per piece			
	[bar]	[bar]	[bar]	[bar]	[bar]	[bar]	[bar]	[bar]	[bar]	[bar]			
	[kg/cm ²]	[kg/cm ²]	[kg/cm ²]	[kg/cm ²]	[kg/cm ²]	[kg/cm ²]	[kg/cm ²]	[kg/cm ²]	[kg/cm ²]	[kg/cm ²]			
Piston and make-up weight	1	1	1	2	1	1	10	1	1	20	1	1	20
Standard mass set	4	20	4	50	5	10	100	4	10	200	5	10	200
	1	18	1	45	1	9	90	1	9	180	1	9	180
	1	10	1	25	1	5	50	1	5	100	1	5	100
	2	4	2	10	2	2	20	2	2	40	2	2	40
	1	2	1	5	1	1	10	1	1	20	1	1	20
	2	1	1	3	1	0.5	5	1	0.5	10	1	0.5	10
Set of fine increment masses (optional)	1	0.4	2	1	2	0.2	2	2	0.2	4	2	0.2	4
	1	0.2	1	0.5	1	0.1	1	1	0.1	2	1	0.1	2
	1	0.1	1	0.25	1	0.05	0.5	1	0.05	1	1	0.05	1
	2	0.04	2	0.1	2	0.02	0.2	2	0.02	0.4	2	0.02	0.4
	1	0.02	1	0.05	1	0.01	0.1	1	0.01	0.2	1	0.01	0.2

Measuring range [psi] or [lb/in ²]	Single-piston measuring ranges				Dual-piston measuring ranges								
	10 ... 1,600		30 ... 4,000		10 ... 10,000			10 ... 16,000			10 ... 20,000		
	Quantity	Nominal pressure per piece	Quantity	Nominal pressure per piece	Quantity	Nominal pressure per piece	Nominal pressure per piece	Quantity	Nominal pressure per piece	Nominal pressure per piece	Quantity	Nominal pressure per piece	Nominal pressure per piece
	[psi] [lb/in ²]		[psi] [lb/in ²]		[psi] [lb/in ²]	[psi] [lb/in ²]		[psi] [lb/in ²]	[psi] [lb/in ²]		[psi] [lb/in ²]	[psi] [lb/in ²]	
Piston	1	10			1	10	100	1	10	200	1	10	200
Piston and make-up weight			1	30									
Standard mass set	6	200	6	500	8	100	1,000	6	100	2,000	8	100	2,000
	1	180	1	450	1	90	900	1	90	1,800	1	90	1,800
	1	100	1	250	1	50	500	1	50	1,000	1	50	1,000
	2	40	2	100	2	20	200	2	20	400	2	20	400
	1	20	1	50	1	10	100	1	10	200	1	10	200
	2	10	1	25	1	5	50	1	5	100	1	5	100
	1	5	1	20									
Set of fine increment masses (optional)	1	4	2	10	2	2	20	2	2	40	2	2	40
	1	2	1	5	1	1	10	1	1	20	1	1	20
	1	1	1	2.5	1	0.5	5	1	0.5	10	1	0.5	10
	2	0.4	2	1	2	0.2	2	2	0.2	4	2	0.2	4
	1	0.2	1	0.5	1	0.1	1	1	0.1	2	1	0.1	2

Measuring range [kPa]	Single-piston measuring ranges				Dual-piston measuring ranges								
	100 ... 12,000		200 ... 30,000		100 ... 70,000			100 ... 120,000			100 ... 140,000		
	Quantity	Nominal pressure per piece	Quantity	Nominal pressure per piece	Quantity	Nominal pressure per piece	Nominal pressure per piece	Quantity	Nominal pressure per piece	Nominal pressure per piece	Quantity	Nominal pressure per piece	Nominal pressure per piece
	[kPa]		[kPa]		[kPa]	[kPa]		[kPa]	[kPa]		[kPa]	[kPa]	
Piston and make-up weight	1	100	1	200	1	100	1,000	1	100	2,000	1	100	2,000
Standard mass set	4	2,000	4	5,000	5	1,000	10,000	4	1,000	20,000	5	1,000	20,000
	1	1,800	1	4,500	1	900	9,000	1	900	18,000	1	900	18,000
	1	1,000	1	2,500	1	500	5,000	1	500	10,000	1	500	10,000
	2	400	2	1,000	2	200	2,000	2	200	4,000	2	200	4,000
	1	200	1	500	1	100	1,000	1	100	2,000	1	100	2,000
	2	100	1	300	1	50	500	1	50	1,000	1	50	1,000
	1	50	1	250									
Set of fine increment masses (optional)	1	40	2	100	2	20	200	2	20	400	2	20	400
	1	20	1	50	1	10	100	1	10	200	1	10	200
	1	10	1	25	1	5	50	1	5	100	1	5	100
	2	4	2	10	2	2	20	2	2	40	2	2	40
	1	2	1	5	1	1	10	1	1	20	1	1	20

Specifications

Model CPB5800

Piston-cylinder systems, model CPS5800

Version		Single-piston measuring ranges		Dual-piston measuring ranges		
Measuring range ¹⁾	bar, kg/cm ²	1 ... 120	2 ... 300	1 ... 60 / 10 ... 700	1 ... 60 / 20 ... 1,200	1 ... 60 / 20 ... 1,400
Required masses	kg	49.7	49.6	57.4	49.2	57.4
Smallest step ²⁾ (Standard mass sets)	bar, kg/cm ²	0.5	2.5	0.5 / 5.0	0.5 / 10	0.5 / 10
Smallest step ³⁾ (Set of fine increment masses)	bar, kg/cm ²	0.02	0.05	0.01 / 0.1	0.01 / 0.2	0.01 / 0.2
Nominal cross-sectional area of the piston	cm ²	0.4032	0.1613	0.8065 / 0.0807	0.8065 / 0.0403	0.8065 / 0.0403
Measuring range ¹⁾	psi, lb/in ²	10 ... 1,600	30 ... 4,000	10 ... 800 / 100 ... 10,000	10 ... 800 / 200 ... 16,000	10 ... 800 / 200 ... 20,000
Required masses	kg	45.5	45.3	56.4	45	56.4
Smallest step ²⁾ (Standard mass sets)	psi, lb/in ²	5	20	5 / 50	5 / 100	5 / 100
Smallest step ³⁾ (Set of fine increment masses)	psi, lb/in ²	0.2	0.5	0.1 / 1	0.1 / 2	0.1 / 2
Nominal cross-sectional area of the piston	cm ²	0.4032	0.1613	0.8065 / 0.0807	0.8065 / 0.0403	0.8065 / 0.0403
Measuring range ¹⁾	kPa	100 ... 12,000	200 ... 30,000	100 ... 6,000 / 1,000 ... 70,000	100 ... 6,000 / 2,000 ... 120,000	100 ... 6,000 / 2,000 ... 140,000
Required masses	kg	49.7	49.6	57.4	49.2	57.4
Smallest step ²⁾ (Standard mass sets)	kPa	50	250	50 / 500	50 / 1,000	50 / 1,000
Smallest step ³⁾ (Set of fine increment masses)	kPa	2	5	1 / 10	1 / 20	1 / 20
Nominal cross-sectional area of the piston	cm ²	0.4032	0.1613	0.8065 / 0.0807	0.8065 / 0.0403	0.8065 / 0.0403

Accuracies

Standard ^{4) 5) 6)}	% of reading	0.015	0.015	0.015	0.015	0.025
Premium ^{4) 5) 7)}	% of reading	0.007	0.006	0.006	0.007	0.007

Pressure transmission medium

Standard		Hydraulic fluid based on VG22 mineral oil				
Optional		Sebacate oil Brake fluid Skydrol Fomblin oil	Sebacate oil Brake fluid Skydrol Fomblin oil	Sebacate oil Brake fluid Skydrol Fomblin oil	Sebacate oil Brake fluid Skydrol Fomblin oil	Sebacate oil

Material

Piston		Steel	Steel	Tungsten car- bide / steel	Tungsten car- bide / steel	Tungsten car- bide / steel
Cylinder		Bronze	Steel	Steel / tungsten carbide	Steel / tungsten carbide	Steel / tungsten carbide
Mass set		Stainless steel, non-magnetic				

Weight

Piston-cylinder system	kg	1	0.8	2	2	2
Storage case for piston-cylinder system	kg	3.1				

- Theoretical starting value; corresponds to the pressure value generated by the piston or the piston and its make-up weights (by their own weight). To optimise the operating characteristics more masses should be loaded.
- The smallest pressure change value that can be achieved based on the standard mass set. To reduce this, a set of fine increment masses is also available.
- The smallest pressure change value that can be achieved based on the optional set of fine increment masses. For further reductions, an accessory set of class M1 or F1 trim masses is available.
- The accuracy from 10 % of the measuring range is based on the measured value. In the lower range, the accuracy is 0.03 % of reading for the single-range piston-cylinder systems and 0.025 % of reading for dual-range piston-cylinder systems.
- Measurement uncertainty assuming reference conditions (ambient temperature 20 °C, air pressure 1013 mbar, relative humidity 40 %). For operation without a CalibratorUnit, corrections must be made if required.
- Not available with UKAS area and mass calibration.
- Requires UKAS area and mass calibration.

Piston-cylinder systems, model CPS5800

Version

Single-piston measuring ranges

Dual-piston measuring ranges

Weight

BAR standard mass sets (in 2 wooden cases)	kg	61.3	61.2	69	60.8	69
PSI standard mass sets (in 2 wooden cases)	kg	57.1	56.9	68	56.6	68
BAR set of fine increment masses	kg	0.33	0.5	0.5	0.5	0.5
PSI set of fine increment masses	kg	0.23	0.34	0.34	0.34	0.34

Dimensions

Carrying case for standard mass sets	400 x 310 x 310 mm (W x H x D)
Storage case for piston-cylinder systems (optional)	300 x 265 x 205 mm (W x H x D)

Base, model CPB5800

Base version

Hydraulic standard	up to a max. 1,200 bar / 16,000 psi; with internal pressure generation
Hydraulic high-pressure	up to a max. 1,400 bar / 20,000 psi; with internal pressure generation

Pressure transmission medium

Standard	Hydraulic fluid based on VG22 mineral oil
Optional	Sebacate oil, brake fluid, Skydrol or Fomblin oil (dependant upon measuring range)
Oil reservoir	250 cm ³

Connections

Connection for piston-cylinder system	G 3/4 male / optional: ConTect quick-release connector (not for 1,400 bar version)
Test item connector	G 1/2 B female quick connector as standard, freely rotating, changeable (for other threaded inserts, see accessories)

Material

Piping in instrument base	1.4404 stainless steel, 6 x 2 mm
---------------------------	----------------------------------

Weight

Standard hydraulic base	18.0 kg / 19.0 kg (incl. optional ConTect quick-release connector)
Hydraulic high-pressure base	18.0 kg
Storage case for the base	8.5 kg

Permissible ambient conditions

Operating temperature	18 ... 28 °C
-----------------------	--------------

Dimensions

Base	400 x 375 x 265 mm (W x D x H), for details, see technical drawings
------	---

CE conformity and certificates

CE conformity

Pressure equipment directive 97/23/EC (Module A)

Certificate

Calibration Calibration certificate
Option: UKAS calibration certificate ^{1) 2)}

- 1) For standard accuracy UKAS calibration certificate only available as pressure calibration.
2) Premium accuracy requires UKAS area and mass calibration.

Approvals and certificates, see website

Transport dimensions for complete instrument

The complete instrument, in its standard version and standard scope of delivery, consists of 3 packages on a single pallet.

The dimensions are 1,200 x 800 x 500 mm.

The overall weight is dependant on the measuring range

Version in bar	Weight in kg	
	net	gross
Single-piston measuring ranges		
1 ... 120 bar	81.5	100
2 ... 300 bar	81.5	100
Dual-piston measuring ranges		
1 ... 60 bar / 10 ... 700 bar	90	108.5
1 ... 60 bar / 20 ... 1.200 bar	82	100.5
1 ... 60 bar / 20 ... 1.400 bar	90	108.5

Version in psi	Weight in kg	
	net	gross
Single-piston measuring ranges		
10 ... 1.600 psi	77.5	96
30 ... 4.000 psi	77	95.5
Dual-piston measuring ranges		
10 ... 800 psi / 100 ... 10.000 psi	89	107.5
10 ... 800 psi / 200 ... 16.000 psi	77.5	96
10 ... 800 psi / 200 ... 20.000 psi	89	107.5

Dimensions in mm

The picture shows a 1,200 bar version of the CPB5800 instrument base with the ConTect quick-release connector option. The 1,400 bar high-pressure version does not differ from it dimensionally, only in the arrangement of the control elements.

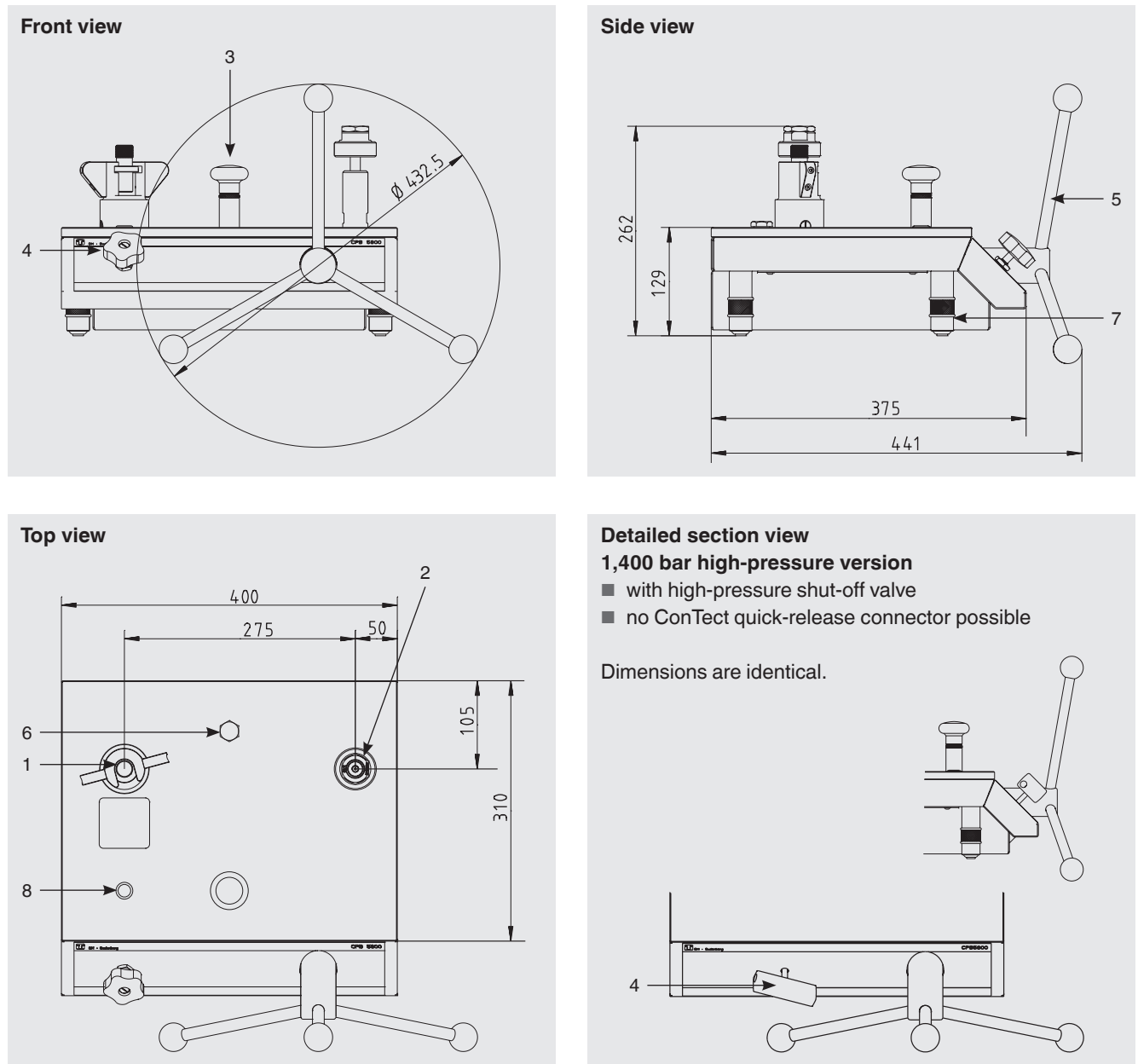

- (1) Connector for piston-cylinder system
- (2) Test item connection
- (3) Priming pump
- (4) Outlet valve
- (5) Spindle pump with star handle, removable
- (6) Oil reservoir sealing screw
- (7) Rotatable feet
- (8) Level

Accessories

Set of trim masses M1 and F1

The masses included in the CPM5800 standard mass set or set of fine increment masses are ideally suited for everyday use. If smaller intermediate values need to be generated, we recommend using a set of class M1 or F1 trim masses, with the following masses:

1 x 50 g, 2 x 20 g, 1 x 10 g, 1 x 5 g, 2 x 2 g, 1 x 1 g,
1 x 500 mg, 2 x 200 mg, 1 x 100 mg, 1 x 50 mg, 2 x 20 mg,
1 x 10 mg, 1 x 5 mg, 2 x 2 mg, 1 x 1 mg



Set of trim masses

Set of adapters for quick connector

As a standard, the pressure balance (dead-weight tester) is equipped with a quick connector for connecting the test item. For this purpose, various threaded adapters, which can be easily changed, are available:

- Adapter set: G ¼, G ⅜, ½ NPT, ¾ NPT and M20 x 1.5
- Adapter set NPT: ⅛ NPT, ¼ NPT, ⅜ NPT and ½ NPT

Additionally the sets of adapters include spare O-rings as well as a spanner with SW32 flats and SW14 flats, for changing the adapters.

Other threaded inserts are available on request.



Set of adapters

Separators

The separators have been specifically designed for measuring instruments, which should not come into contact with the medium of the pressure balance (dead-weight tester) or to protect against contamination of the pressure balance (dead-weight tester) from the test items.



Fig. left: Separator (without diaphragm)

Fig. middle: Separator (with diaphragm) 700 bar

Fig. right: Separator (with diaphragm) 1,200 bar

Designation/Variant	Order no.
Set of trim masses (1 mg up to 50 g), class F1	7093874
Set of trim masses (1 mg up to 50 g), class M1	14025325
Set of adapters for quick connector in case with G ¼, G ⅜, ½ NPT, ¾ NPT and M20 x 1.5 threaded inserts for insertion in the knurled nut on the test item connector	2036941
Set of "NPT" adapters for quick connector in case with ⅛ NPT, ¼ NPT, ⅜ NPT and ½ NPT threaded inserts for insertion in the knurled nut on the test item connector	12563626
90° angle connection, for test items with back mounting connection	1564838
Separator (without diaphragm), max. 1,000 bar	1565389
Separator (to separate two liquid media by a diaphragm), max. 700 bar	14031253
Separator (to separate two liquid media by a diaphragm), max. 1,200 bar	14031254
O-ring set consisting of 5 pcs. 8 x 2 and 5 pcs. 4 x 2.2	12328562
Operating fluid for CPB series up to a max. 4,000 bar, 1 litre	2099882
Adapter for mounting model CPS5800 hydraulic piston-cylinder systems into a ConTect system mechanism	14031252
Test item connection, G ¾ female to G ½ female, rotating, operation as a comparison test pump is possible	14031251
Special test-item adapter with quick connect, for the matching to the ConTect system mechanism, operation as a comparison test pump is possible	2152634
Electrical piston drive unit for 700 bar, 1,200 bar and 1,400 bar measuring ranges (AC 230 V/50 Hz)	14031260

CalibratorUnit model CPU6000

The models of the CPU6000 series are compact tools for use with a pressure balance (dead-weight tester). In particular when highly-accurate measuring values, with measurement uncertainties of less than 0.025 %, are required, complicated mathematical calculations and corrections are necessary. With the CPU6000 in combination with the CPB-CAL (iPad® app) and/or WIKA-CAL (PC software) all critical ambient parameters can be registered and automatically corrected.

The CPU6000 series is made up of three instruments

Weather station, model CPU6000-W

The CPU6000-W provides measured values such as atmospheric air pressure, relative humidity and the ambient temperature of the laboratory environment.

Pressure balance sensor box, model CPU6000-S

The CPU6000-S measures the piston temperature and displays the floating position of the masses.

Digital multimeter, model CPU6000-M

The CPU6000-M fulfills the function of a digital multimeter and power supply unit when electronic pressure transmitters must be calibrated.

Typical application

CPB-CAL iPad® app

The iPad® application calculates the mass loads for pressure balances (dead-weight testers) or the reference pressure while taking the measured parameters from the CPU6000 into account. The conversion can be carried out in all common pressure units. As an additional parameter, the local gravity can be specified for location-independent measurements.

WIKA-CAL PC software - Weight calculator

With the demo version of the WIKA-CAL software and a CPB series pressure balance (dead-weight tester), the mass discs to be applied and the corresponding reference pressure can be determined. The pressure balance data (dead-weight tester data) can be entered into the database manually or imported automatically via an online available XML file. All ambient parameters and piston temperature can be entered manually into WIKA-CAL or can be measured automatically with the CPU6000 series, so that the highest accuracy can be achieved. WIKA-CAL demo version can be downloaded free of charge from the WIKA website.

Further specifications on the CPU6000 series can be found in data sheet CT 35.02.

For details of the WIKA-CAL calibration software see data sheet CT 95.10.



CPU6000 series and iPad® app CPB-CAL



Model CPU6000-W, CPU6000-S, CPB5800 and PC with WIKA-CAL software

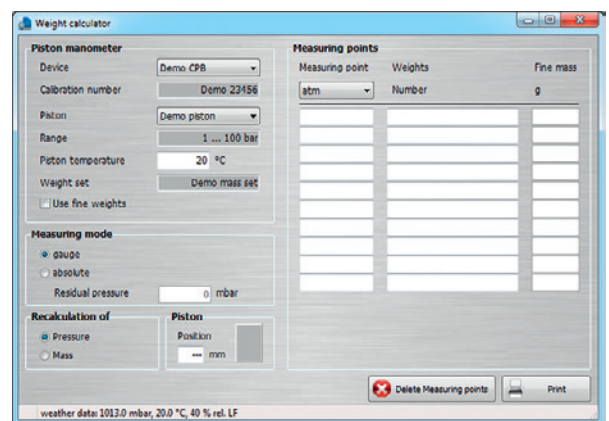

WIKA-CAL PC software - Weight calculator

Further pressure balances (dead-weight testers) within our calibration technology programme

Dead-weight tester, model CPB3800

Measuring ranges:

- Hydraulic 1 ... 120 up to 10 ... 1,200 bar or
10 ... 1,600 up to 100 ... 16,000 psi,
respectively

Accuracy: 0.05 % of measured value
0.025 % of measured value (optional)

For specifications see data sheet CT 31.06



Dead-weight tester, model CPB3800

Pressure balance, model CPB5000

Measuring ranges:

- Pneumatic -0.03 ... -1 up to +0.4 ... +100 bar or
-0.435 ... -14 up to +5.8 ... +1,500 psi,
respectively

Accuracy: 0.015 % of measured value
0.008 % of measured value (optional)

For specifications see data sheet CT 31.01



Pressure balance, model CPB5000

Pressure balance for high pressure, model CPB5000HP

Measuring ranges:

- Hydraulic 25 ... 2,500, 25 ... 4,000 or 25 ... 5,000 bar, or
350 ... 40,000, 350 ... 60,000 or
350 ... 70,000 psi, respectively
- 50 / 2,600 bar dual piston or
600 / 40,000 psi dual piston, respectively

Accuracy: 0.025 % of measured value
0.02 % of measured value (optional)

For specifications see data sheet CT 31.51



Pressure balance for high pressure, model CPB5000HP

Pressure balance for differential pressure, model CPB5600DP

Measuring range = (static pressure + differential pressure):

- Pneumatic 0.03 ... 2 up to 0.4 ... 100 bar or
0.435 ... 30 up to 5.8 ... 1,500 psi,
respectively
- Hydraulic 0.2 ... 60 up to 25 ... 1,600 bar or
2.9 ... 1,000 up to 350 ... 23,200 psi,
respectively

Accuracy: 0.015 % of measured value
0.008 % of measured value (optional)

For specifications see data sheet CT 31.56



Pressure balance for differential pressure, model CPB5600DP

Scope of delivery

- Base with dust protection cover
- Priming pump
- Spindle pump for pressure generation and fine adjustment
- Piston connection with G 3/4 male thread
- Quick connector for test items with G 1/2 female threaded insert, changeable
- Piston-cylinder system
- Standard mass sets in carrying case
- Mass set manufactured to standard gravity (9.80665 m/s²)
- VG22 mineral oil (1.0 litre)
- Operating instructions in German and English language
- Factory calibration certificate

Options

- Other pressure transmission media
- Piston connection with ConTect quick-release connector or M30 x 2 female thread
- System with increased accuracy to 0.006 %
- Other pressure units
- Mass set manufactured to local gravity
- Set of fine increment masses
- Storage case for the base and the piston-cylinder system
- UKAS calibration certificate
- Combination with CPS/CPM5000 series units possible (please contact WIKA sales team for further information)

Ordering information

Instrument base

CPB5800 / Pressure transmission medium / Instrument version / Connection of piston-cylinder system / Mass set / Piston-cylinder system / Installation of CPU6000-S CalibratorUnit sensor technology / Storage case / Additional order information

Piston-cylinder system

CPS5800 / Accuracy / Gravity value g / Measuring range / Connection of piston-cylinder system / Storage case for piston-cylinder system / Calibration of piston-cylinder system / Additional order information

Mass set

CPM5800 / Pressure unit / Gravity value g / Standard mass set / Set of fine increment masses / Calibration of standard mass set / Calibration of the set of fine increment masses / Additional order information

© 2012 WIKA Alexander Wiegand SE & Co. KG, all rights reserved.
The specifications given in this document represent the state of engineering at the time of publishing.
We reserve the right to make modifications to the specifications and materials.

