



CALUS
120 VAC Only
E48329

Timer/Counter with Memory

- EEPROM Memory
- Easy DIP Switch Setup
- Three Adjustable Presets with Internal Cycle Totalizer
- Dual LED Display with Cycle Progress
- Selectable SEC, MIN, or HRS Ranges
- Nine Timing Ranges 0 to 9.99, 99.9, 999, or HR:MIN, MIN:SEC to 99:59
- Two Counting Ranges 0 to 9999 or 10 to 99990
- Multiple Starting Options
- Dual DPDT Relays Rated at 7A @ 120 or 240 VAC
- 50-60 Hz

In the timer mode, the 385 can be programmed to cover the overall span of 0.01 SEC to 999 HR in nine ranges, and can be programmed to time in Hours:Minutes and Minutes:Seconds. In the counter mode, it can cover the overall span of 1 to 99,900 counts in two ranges.

MULTIPLE RELAY ACTIONS: The relationship between the 385's two DPDT relays, Relay 1 and Relay 2 can be programmed for any of the four modes of operation to satisfy virtually any control scheme.

MULTIPLE STARTING OPTIONS: The 385 can be easily programmed to start with a momentary or sustained start signal. The start signal can also be set for a voltage or no voltage starting condition.

NEW TIMING AND COUNTING MODES: The 385 has two new modes of operation. The flip-flop timer/counter with batch, which can be programmed to function as a flip-flop that will stop after a certain number of cycles or a time span. The other new flip-flop function is a standard flip-flop with a programmable dwell between the relays.

DISPLAY: The display is an LED dual display which can be programmed to run UP to or DOWN from the set point. The lower display shows the preset selected to view and the upper display shows the cycle progress.

NON-VOLATILE MEMORY: The 385 retains its entire program and preset time/count periods even when there is a loss of power. No batteries are required.

REAL-TIME COMPUTATIONS: The 385's microcomputer instantly recomputes time/count-out when there is a change in the set point during a cycle. This allows you to shorten a cycle without loss of accuracy.

COMPACT, PLUG-IN AND DUST-TIGHT: Packaged in a 72mm² DIN housing, the 385 takes 40% less panel space than conventional timers. A true plug-in design, it can be replaced in seconds without disturbing housing or wiring. Fully gasketed and sealed, it is dust tight in panel mounted installations. **SETUP:** Setup of the 385 is accomplished using 16 DIP switches which are located inside the unit. These DIP switches give a visual indication of how the Controller is setup, and eliminates the use of complex programming codes.

DIMENSIONS (INCHES/MILLIMETERS)

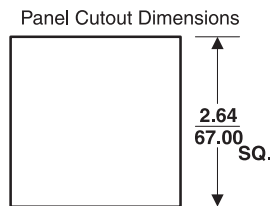
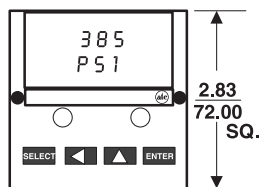
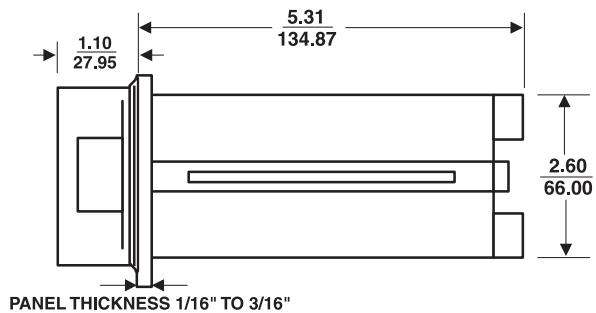

MODEL NUMBER

MODEL NUMBER	385	500		50	P	
RANGE		500				
VOLTAGE & FREQUENCY	120 VAC 50-60 Hz			Q		
	240 VAC, 50-60 Hz			R		
FUNCTION	Programmable			50		
FEATURES	Basic plug-in unit				P	
	Standard unit					X
	Special					K

PRESET SETUP

After you have setup the Controller by programming the DIP switches you must first set DIP switch (8) on the right bank to program mode, this allows you to set the presets 1, 2 and 3, in seconds, minutes, or hours. You must press the "select" button to choose the preset to select. To choose the time range you must select the timing bar "▬" and

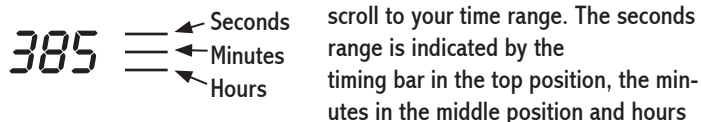

in the bottom position, when used as a counter it will display as a "C". After each selection is made you must press the "enter" button.

Preset 3 can be set up as a count or time input regardless if it is set up as a counter or a timer/counter in Flip-Flop with batch mode.

When setup as a standard timer (DIP switches 2 and 3 up on left bank) you may program the decimal point by scrolling past the left digit and press the up scroll button, this will place the decimal point in the 2 possible places, when finished press the "enter" button and set back to run mode. When the 385 is in the run mode the time from each preset can only be adjusted in the time range with the decimal position you chose while in the program mode.

For users who wish to have no changes allowed in the run mode – see DIP switch setup.

4 MODES OF OPERATION

RELAY ARRANGEMENT 1

Relay 1 energizes before Relay 2 and remains energized when Relay 2 energizes. Both relays drop out simultaneously.

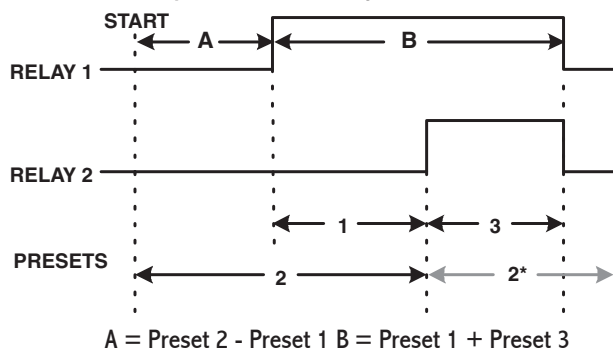

RELAY ARRANGEMENT 2

Relay 1 energizes before Relay 2 and drops out when Relay 2 energizes.

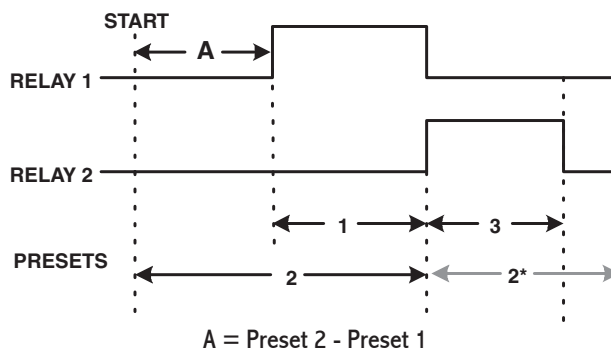

FLIP FLOP TIMER OR COUNTER WITH BATCH

Relay 1 energizes at start and drops out when Relay 2 energizes. Stops at Preset 3 (Batch)

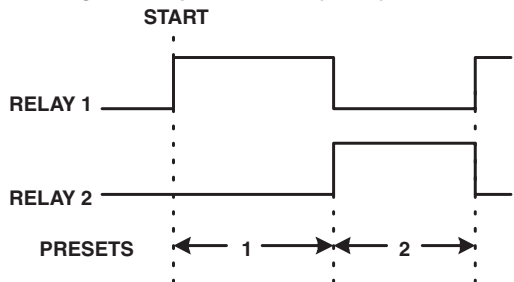

The Timer/Counter will repeat until it reaches the set count or time (Preset 3).

FLIP FLOP TIMER OR COUNTER WITH DWELL SIMILAR TO ATC (306) ACTION

Relay 1 energizes at start then has a dwell (Preset 3) Relay 2 then energizes and drops out. Cycle can repeat or cycle once.

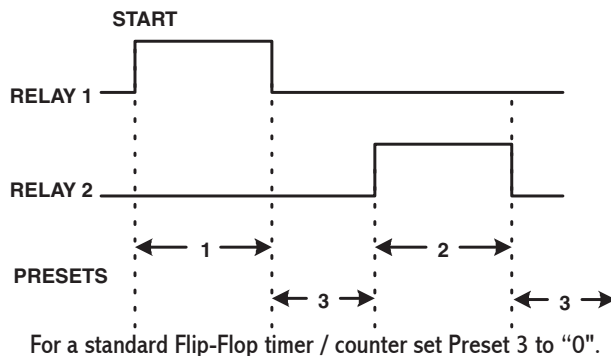

*Note: Relay arrangement 1 and 2 are shown in single cycle only, when used in repeat cycle the relationship between the relays changes, the process restarts after preset 2. The microprocessor automatically calibrates the timer for 50 or 60Hz power operation, there are no switches or jumpers to set.

DIP SWITCH SETUP

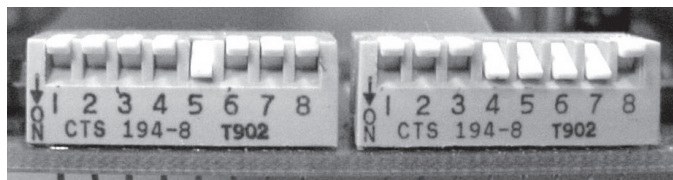

LEFT SWITCH

- 1 Up= Counter
Dn= Timer
- 2 Up= Counter or Standard Timer
Dn= Minutes:Seconds (Timer Only)
- 3 Up= Counter or Standard Timer
Dn= Hours:Minutes (Timer Only)
- 4 5
Up Display preset 1 (PS1)
Up Dn Display preset 2 (PS2)
Dn Up Display preset 3 (PS3)
Dn Dn Display preset 4 Totalizer (PS4)
- 6 Up= Count/Time Down
Dn= Count/Time Up
- 7 Up= Changes in run mode allowed
Dn= No Changes in run mode allowed
- 8 Up= (Normal) X 1
Dn= X 10 prescaler (Counter Only)

RIGHT SWITCH

- 1 Up= Non-Memory (reset on power failure)
Dn= Memory (no reset on power failure)
- 2 Up= Repeat Cycle
Dn= Single Cycle
- 3 Up= Momentary Start
Dn= Sustained Start
- 4 Up= Voltage Start (close to start, open to reset)
Dn= No Voltage Start (open to start, close to reset)
- 5 6
Up Relay Arrangement # 1
Dn Relay Arrangement # 2
Up Relay Arrangement # 2
Dn Flip Flop with Dwell
Dn Flip Flop with Batch
- 7 Up= Normal Operation
Dn= Self Test (Displays all 8's)
- 8 Up= Program Mode
Dn= Run Mode

OPERATION

THE DISPLAY: A highly visible dual display consists of three digits with a movable decimal point or four digits for counting. There is a horizontal timing bar "■" which appears to the right of the upper display and blinks once per second during timing. This is very useful in showing that the timer is timing especially when the digits do not change rapidly as in the hours ranges. The timing bar blinks rapidly at time-out as well. The lower display is DIP switch selectable to display the preset time or counts for any one of the four presets, and the upper display will show that presets cycle progress.

UNDERSTANDING THE PRESETS: There are three programmable presets, Preset 1, Preset 2, and Preset 3. There is a totalizer for each mode of operation, this preset is designated Preset 4. This preset is for display only and increments a count at the end of each cycle, to reset the totalizer to zero you must go into programming mode (see DIP SWITCH SETUP) and set all four digits to zero. Once the totalizer reaches 9999 it will go to E000, the maximum count is E999 which actually has a count value of 10999. When changing or setting a preset in run mode, the display will revert back to the running time after a button has not been used for 10 seconds.

FUNCTIONS: To use the 385 you must apply power to terminals 16 and 2, terminal 1 is the start/reset or momentary start input terminal. You must also apply voltage to terminal 15 (clock/count input) to start timing or place a count, if power is removed from terminal 15 when you are timing the 385 will stop where it is and continue when power is reapplied to terminal 15. The 385 was designed to replace most of the functions of the ATC model 375. Most of these functions can be done with the relay arrangement 1 and 2 modes of operation. The arrangement 3 mode was not implemented, and most arrangement 3 applications can be done with the flip-flop mode of operation. The 385 can function as a ON-Delay or OFF-Delay timer or counter in arrangement 1, (ATC model 365, 366) to allow this, preset 1 and preset 3 must be set to 999 hours, the 385 will interpret this as infinite time and display as "INF". Preset 2 will be the set time and allow a setting of 999 hours. Relay 1 will act as an instantaneous relay, and Relay 2 as a delayed relay. The 385 when set as a standard timer operates in hours, minutes, and seconds with a movable decimal point, also the 385 can operate in hours:minutes and minutes:seconds with a maximum setting of 99:59 (see DIP SWITCH SETUP).

NEW MODES OF OPERATION: The 385 can perform as a Flip-Flop timer or counter with batch. Preset 1 is the first set time and Preset 2 is the second set time. Preset 3 is the batch, which it stops at after a certain number of flip-flop cycles up to 999, or stops at any desired time. In this mode you cannot use the hours:minutes and minutes:seconds operation. The other new mode of operation is the Flip-Flop timer or counter with dwell. This is the mode to be used when a standard Flip-Flop is needed. This new mode is designed to have a first set time (Preset 1) then a dwell time (Preset 3) followed by the second set time (Preset 2), when used in repeat cycle there is a dwell after Preset 2 also. To use as a standard Flip-Flop set the dwell time to "0". All of the modes can be set for a voltage or no voltage start, momentary or sustained start, and repeat or single cycles.

WIRING

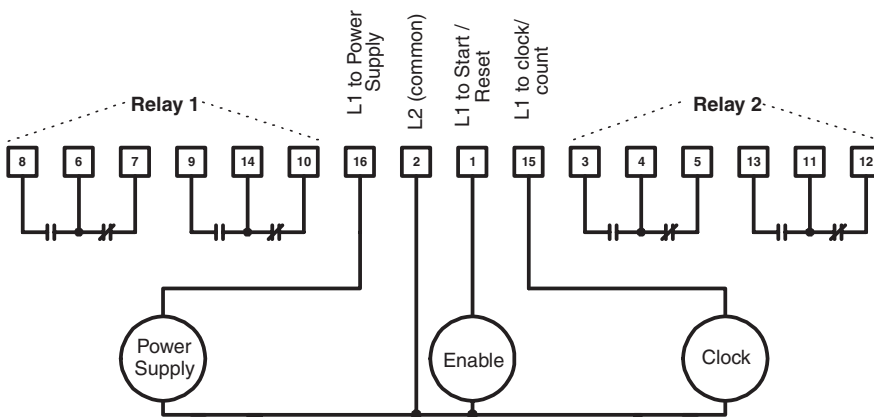

TERMINAL WIRING

