

Data Sheet

8009S Pressure Gauge

FEATURES

- Removable bayonet ring allows for gauge recalibration
- Meets EN837-1 and ASME B40.100 specifications
- R110 & NGV 3.1 Approvals
- FlutterGuard™ standard on dry gauges
- Custom dials available
- Accessory kits for easy panel mounting
- Designed to meet MSL Helium leak test of 1×10^{-6} scc/s

TYPICAL USES

- Hydraulic systems
- Food and beverage
- Compressors and pumps
- Irrigation equipment
- Refrigerant applications
- Compressed and liquid natural gas applications
- Hydrogen cell, H₂ gas applications



8009S
100 mm

8009S
63 mm

SPECIFICATIONS

Accuracy:	63 mm:	±1.6% of span per EN837-1 ±1% of span per EN837-1 (thru 10,000 psi) ±2-1-2% of span ASME B40.100 (thru 10,000 psi)
	100 mm:	±1% of span per EN837-1 (thru 10,000 psi) ±1.6% of span per EN837-1

Dial Sizes: 63 mm (2½"); 100 mm (4")

Ranges: Vacuum, compound, 15 to 20,000 psi, bar, kPa, MPa, kg/cm², (available in single or dual scale)

Working Pressure: **Steady:** 75% full-scale value
Fluctuating: 80% full-scale value
Short Time: full-scale value

Over Pressure/ Proof Pressure: ≤100 bar ranges: 125% of maximum scale value
>100 to ≤600 bar ranges: 115% of maximum scale value
>600 to ≤1400 bar ranges: 110% of maximum scale value

Process Connection Location: 63 mm: Lower, center back or lower back
100 mm: Lower, center back or lower back

Process Connection Sizes: 63 mm: ¼ NPT, ¼ NPT, G¼ B, ¼ BSPT, SAE-4 ¼₁₆-20, M14x1.5, #4JIC, ¼ Tube stub male, ⅜ Tube stub male, ½ Tube stub male
100 mm: ¼ NPT, ½ NPT, G¼ B, G½ B, M14x1.5, M20x1.5, ¼ BSPT, ½ BSPT, ¼ Tube stub male, ⅜ Tube stub male, ½ Tube stub male, ¼ High pressure female

Dial: Black figures on white background (blue secondary scale for dual scale dials); aluminum

Pointer: Black, aluminum

Movement: 316 Stainless steel

Dampening: FlutterGuard™, Glycerin fill, Silicone fill

Temperature Effects: ±0.04% of span per °C change; reference temp. 20 °C
±0.4% of span per 18 °F change; reference temp. 68 °F

Approvals: CE/UKCA, RoHS (EU Directives 2011/65/EU and 2015/863); PED (2014/68/EU); R110; NGV 3.1 IP66 rating; NEMA 4X for water and dust ingress

CSA/ANSI NGV 3.1:20 PXX

(E4)110R-050565"L"



KEY BENEFITS

- Corrosion resistant
- Economical all stainless steel gauge
- Customizable for new applications
- Available in a variety of connections and ranges

WETTED COMPONENTS

Bourdon Tube	Process Connection	Restrictor
316 SS Laser Welded	316 SS Laser Welded	SS (0.013" orifice)

NON-WETTED COMPONENTS

Case	Window	Ring
304 SS, open front (STD.)	Polycarbonate, glass, or safety glass	304 SS, bayonet (STD.)
316 SS, open front (OPT.)	Polycarbonate, glass, or safety glass	316 SS, bayonet (OPT.)

MIN/MAX TEMPERATURE LIMITS

Version	Ambient	Process	Storage
Dry with FlutterGuard™	-40 °F to 200 °F (-40 °C to 93 °C)	-40 °F to 250 °F (-40 °C to 121 °C)	-40 °F to 200 °F (-40 °C to 93 °C)
Glycerin Fill	20 °F to 158 °F (-7 °C to 70 °C)	-4 °F to 212 °F (-20 °C to 100 °C)	-40 °F to 158 °F (-40 °C to 70 °C)
Silicone Fill	-40 °F to 158 °F (-40 °C to 70 °C)	-40 °F to 212 °F (-40 °C to 100 °C)	-40 °F to 158 °F (-40 °C to 70 °C)

Data Sheet

8009S Pressure Gauge

ORDERING CODE	Example:	63	8009S	4	G	02	L	P	0	L	10BR	XWP
Dial Size												
63 - 63 mm / 2½"		63										
10 - 100 mm / 4"												
Model												
8009S - Pressure gauge			8009S									
Case/Ring Material												
4 - 304 Stainless steel				4								
6 - 316 Stainless steel												
Fill												
F - Dry with FlutterGuard™												
G - Glycerine filled					G							
S - Silicone filled												
N - Dry, silicone free												
T - Dry, with silicone free FlutterGuard™												
Process Connection Sizes (See Table on page 3 for more options)												
02 - ¼ NPT Male						02						
Process Connection Location												
B - Lower back												
C - Center back												
D - 3 o'clock (right side)												
E - 9 o'clock (left side)												
L - Lower							L					
T - Top												
Window Material												
P - Polycarbonate								P				
R - Regular glass												
S - Safety glass												
Case Mounting												
0 - Stem mounting									0			
1 - U-clamp (center back only; connection mounted)												
2 - Front flange (lower back and center back only)												
3 - Rear flange												
4 - Front flange and U-clamp (center back only; connection mounted)												
5 - Trim ring and U-clamp (center back only; connection mounted)												
6 - U-clamp (lower back and center back only; case mounted)												
8 - Front flange and U-clamp (lower back and center back only; case mounted)												
9 - Trim ring and U-clamp (lower back and center back only; case mounted)												
Accuracy												
J - ±1% of span (not available in 15,000 psi or 20,000 psi)												
L - ±1.6% of span										L		
M - ±2-1-2% of span (not available in 15,000 psi or 20,000 psi)												
Ranges (coding example only, see Table 1 for all standard ranges)												
10BR - Black primary and secondary dial scales on white background											10BR	
Options (If choosing an option(s) must include an "X") (See Table on page 3 for more options)												
WP - Omit restrictor												XWP

8009S Pressure Gauge

Process Connection Size Table

Connection Code	Process Connection
01	1/8 NPT Male (63 mm only)
02	1/4 NPT Male
04	1/2 NPT Male (100 mm only)
09	1/4 High pressure, female (recommended for 20,000 psi, 100 mm only)
13	G1/4 B Male
15	G1/2 B Male (100 mm only)
16	M20x1.5 (100 mm only)
41	M14x1.5 (63 mm only)
EJ	#4JIC (63 mm only)
KA	1/4 BSPT
KD	1/2 BSPT (100 mm only)
JP	1/4" Tube stub, male (not available on 15,000 psi or 20,000 psi)
JR	3/8" Tube stub, male (not available on 15,000 psi or 20,000 psi)
JS	1/2" Tube stub, male (not available on 15,000 psi or 20,000 psi)
RW	SAE-4 7/16-20 (63 mm only) (not available on 15,000 psi or 20,000 psi)

Options (If choosing an option(s) must include an "X")

AR - Adjustable red indicator and min/max drag pointer (63 mm dry gauge only)

BM - Black primary and secondary dial scales on white background

CR - Custom individual carton label information

RM - Black primary and red secondary dial scales on white background

WP - Omit restrictor

ZO - Bulk packaging

ZP - Customer part number and description on Ashcroft label

ZQ - Customer part number only (no Ashcroft®)

ZW - Customer part number and gauge description on label (no Ashcroft identification)

B1 - Black protective boot (63 mm only, lower connect or center back connect only)

S2 - Safety pattern gauge without baffle wall; designed by S2 per EN837-1 (only available on 63 mm gauge having a polycarbonate window)

99 - Serial number on dial

ML - Mass spectrometer leak test

R5 - Ammonia refrigerant dial (30IMV&150#, 30IMV&300#)

8N - NGV 3.1 Approval on dial

8R - R110 Approval on dial

Data Sheet

8009S Pressure Gauge

TABLE 1 - COMMERCIAL GAUGE RANGES

psi	bar	kPa	Mpa	kg/cm ²	NOTES
30IMV	-1BR	-100KP	-.1MP	-1KSC	
-	-1&.6BR	-100&60KP	-.1&.06MP	-1&.6KSC	
V&15#	-	-	-	-	
-	-1&1.5BR	-100&150KP	-.1&.15MP	-1&1.5KSC	
V&30#	-	-	-	-	
-	-1&3BR	-100&300KP	-.1&.3MP	-1&3KSC	
V&60#	-	-	-	-	
-	-1&5BR	-100&500KP	-.1&.5MP	-1&5KSC	
V&100#	-	-	-	-	
V&150#	-	-	-	-	
V&300#	-	-	-	-	
-	-1&9BR	-100&900KP	-.1&.9MP	-1&9KSC	
15#	1BR	100KP	.1MP	1KSC	
20#	-	-	-	-	
-	1.6BR	160KP	.16MP	1.6KSC	
30#	-	-	-	-	
-	2.5BR	250KP	.25MP	2.5KSC	
60#	4BR	400KP	.4MP	4KSC	
-	6BR	600KP	.6MP	6KSC	
100#	-	-	-	-	
120#	-	-	-	-	
-	10BR	1,000KP	1MP	10KSC	
160#	-	-	-	-	
200#	-	-	-	-	
-	16BR	1,600KP	1.6MP	16KSC	
300#	-	-	-	-	
-	25BR	2,500KP	2.5MP	25KSC	
400#	-	-	-	-	
500#	-	-	-	-	
600#	40BR	4,000KP	4MP	40KSC	
-	60BR	6,000KP	6MP	60KSC	
1000#	-	-	-	-	
1500#	100BR	10,000KP	10MP	100KSC	
2000#	-	-	-	-	
-	160BR	16,000KP	16MP	160KSC	
3000#	-	-	-	-	
-	250BR	25,000KP	25MP	250KSC	
4000#	-	-	-	-	
5000#	-	-	-	-	
6000#	400BR	40,000KP	40MP	400KSC	
7500#	-	-	-	-	
-	600BR	60,000KP	60MP	600KSC	
10000#	-	-	-	-	
15000#	1000BR	100,000KP	100MP	1,000KSC	Only available with $\pm 1.6\%$ of span accuracy. This range is not CRN registered.
20000#	-	-	-	-	Only available with $\pm 1.6\%$ of span accuracy. This range is not CRN registered.

8009S Pressure Gauge

DIMENSIONS in [] are millimeters

For reference only, consult Ashcroft for specific dimensional drawings

100 mm lower connect - stem mount		
Connection Code	Process Connection	Height
02	¼ NPT	5.56 [141.2]
04	½ NPT	5.61 [142.4]
09	¼ HP Female	5.61 [142.4]
13	G¼ B	5.48 [139.1]
15	G½ B	5.72 [145.4]
16	M20x1.5	5.72 [145.4]
JP	¼ Tube	5.59 [141.9]
JR	⅜ Tube	5.72 [143.8]
JS	½ Tube	5.75 [146.1]
KA	¼ BSPT or R ¼	5.41 [137.5]
KD	½ BSPT or R ½	5.61 [142.4]

100 mm lower connect - rear flange		
Connection Code	Process Connection	Height
02	¼ NPT	5.56 [141.2]
04	½ NPT	5.61 [142.4]
09	¼ HP Female	5.61 [142.4]
13	G¼ B	5.48 [139.1]
15	G½ B	5.72 [145.4]
16	M20x1.5	5.72 [145.4]
JP	¼ Tube	5.59 [141.9]
JR	⅜ Tube	5.72 [145.2]
JS	½ Tube	5.75 [146.1]
KA	¼ BSPT or R ¼	5.41 [137.5]
KD	½ BSPT or R ½	5.61 [142.4]

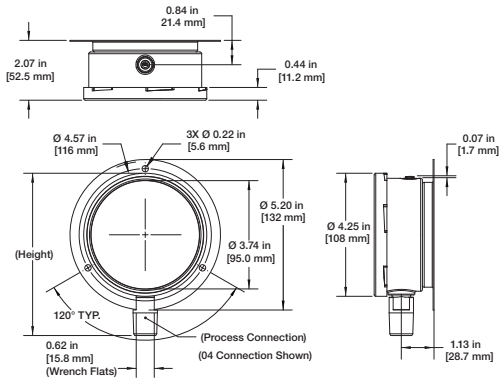
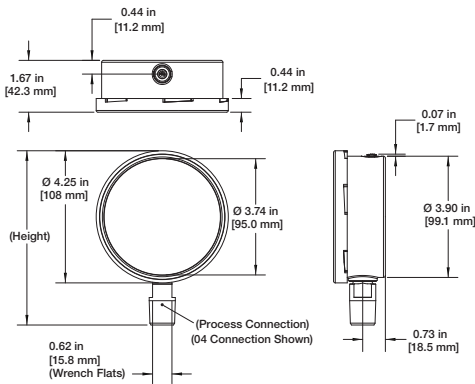

100 mm lower back connect - stem mount		
Connection Code	Process Connection	Depth
02	¼ NPT	3.15 [80.0]
04	½ NPT	3.20 [81.2]
09	¼ HP Female	3.20 [81.2]
13	G¼ B	3.07 [77.9]
15	G½ B	3.31 [84.2]
16	M20x1.5	3.31 [84.2]
JP	¼ Tube	3.18 [80.7]
JR	⅜ Tube	3.31 [84.0]
JS	½ Tube	3.34 [84.9]
KA	¼ BSPT or R ¼	3.00 [76.3]
KD	½ BSPT or R ½	3.20 [81.2]

100 mm lower back connect - panel mount, case		
Connection Code	Process Connection	Depth
02	¼ NPT	3.15 [80.0]
04	½ NPT	3.20 [81.2]
09	¼ HP Female	3.20 [81.2]
13	G¼ B	3.07 [77.9]
15	G½ B	3.31 [84.2]
16	M20x1.5	3.31 [84.2]
JP	¼ Tube	3.18 [80.7]
JR	⅜ Tube	3.31 [84.0]
JS	½ Tube	3.34 [84.9]
KA	¼ BSPT or R ¼	3.00 [76.3]
KD	½ BSPT or R ½	3.20 [81.2]

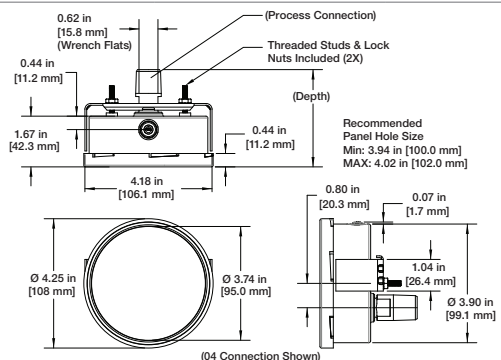
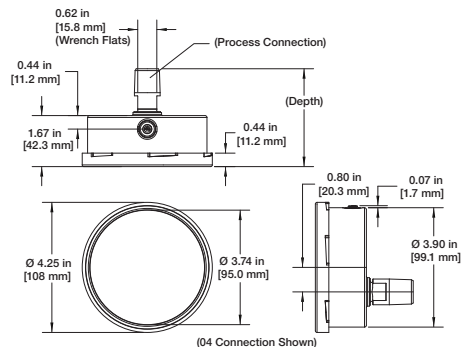

Data Sheet

8009S Pressure Gauge

DIMENSIONS in [] are millimeters

For reference only, consult Ashcroft for specific dimensional drawings

100 mm lower back connect - front flange

Connection Code	Process Connection	Depth
02	¼ NPT	3.15 [80.0]
04	½ NPT	3.20 [81.2]
09	¼ HP Female	3.20 [81.2]
13	G¼ B	3.07 [77.9]
15	G½ B	3.31 [84.2]
16	M20x1.5	3.31 [84.2]
JP	¼ Tube	3.18 [80.7]
JR	⅜ Tube	3.31 [84.0]
JS	½ Tube	3.34 [84.9]
KA	¼ BSPT or R ¼	3.00 [76.3]
KD	½ BSPT or R ½	3.20 [81.2]

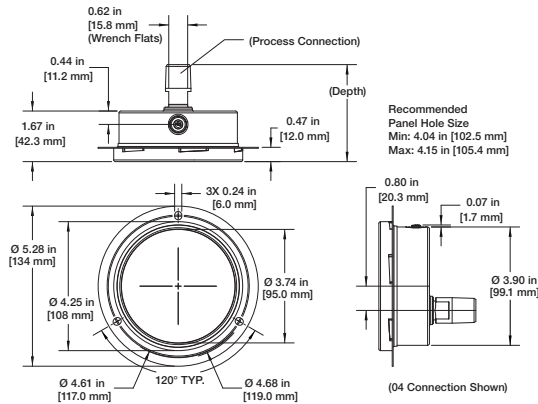

100 mm lower back connect - panel mount case, front flange

Connection Code	Process Connection	Depth
02	¼ NPT	3.15 [80.0]
04	½ NPT	3.20 [81.2]
09	¼ HP Female	3.20 [81.2]
13	G¼ B	3.07 [77.9]
15	G½ B	3.31 [84.2]
16	M20x1.5	3.31 [84.2]
JP	¼ Tube	3.18 [80.7]
JR	⅜ Tube	3.31 [84.0]
JS	½ Tube	3.34 [84.9]
KA	¼ BSPT or R ¼	3.00 [76.3]
KD	½ BSPT or R ½	3.20 [81.2]

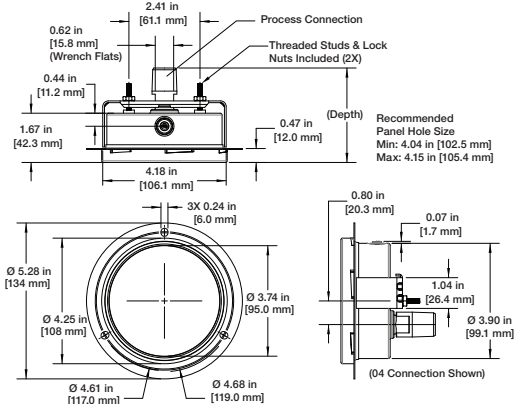

100 mm lower back connect - panel mount case, trim ring

Connection Code	Process Connection	Depth
02	¼ NPT	3.15 [80.0]
04	½ NPT	3.20 [81.2]
09	¼ HP Female	3.20 [81.2]
13	G¼ B	3.07 [77.9]
15	G½ B	3.31 [84.2]
16	M20x1.5	3.31 [84.2]
JP	¼ Tube	3.18 [80.7]
JR	⅜ Tube	3.31 [84.0]
JS	½ Tube	3.34 [84.9]
KA	¼ BSPT or R ¼	3.00 [76.3]
KD	½ BSPT or R ½	3.20 [81.2]

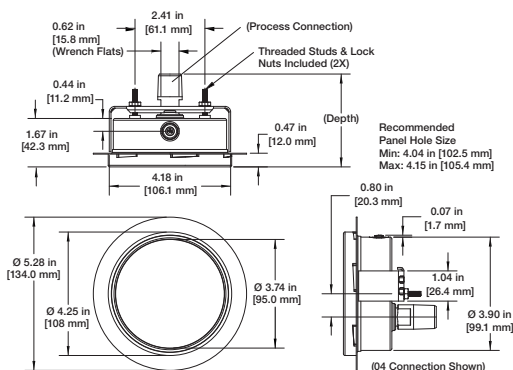

100 mm lower back connect - rear flange

Connection Code	Process Connection	Depth
02	¼ NPT	3.15 [80.0]
04	½ NPT	3.20 [81.2]
09	¼ HP Female	3.20 [81.2]
13	G¼ B	3.07 [77.9]
15	G½ B	3.31 [84.2]
16	M20x1.5	3.31 [84.2]
JP	¼ Tube	3.18 [80.7]
JR	⅜ Tube	3.31 [84.0]
JS	½ Tube	3.34 [84.9]
KA	¼ BSPT or R ¼	3.00 [76.3]
KD	½ BSPT or R ½	3.20 [81.2]

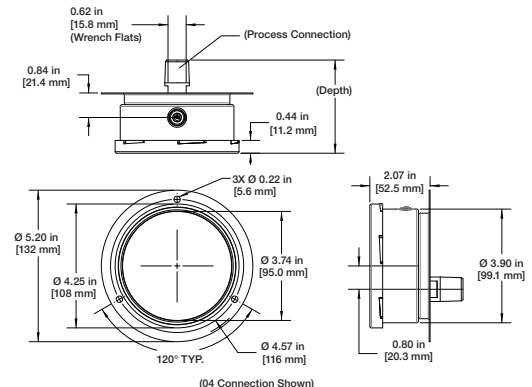

8009S Pressure Gauge

DIMENSIONS in [] are millimeters

For reference only, consult Ashcroft for specific dimensional drawings

100 mm center back connect - stem mount		
Connection Code	Process Connection	Depth
02	¼ NPT	3.15 [80.0]
04	½ NPT	3.20 [81.2]
09	¼ HP Female	3.20 [81.2]
13	G¼ B	3.07 [77.9]
15	G½ B	3.31 [84.2]
16	M20x1.5	3.31 [84.2]
JP	¼ Tube	3.18 [80.7]
JR	⅜ Tube	3.31 [84.0]
JS	½ Tube	3.34 [84.9]
KA	¼ BSPT or R ¼	3.00 [76.3]
KD	½ BSPT or R ½	3.20 [81.2]

100 mm center back connect - panel mount, socket		
Connection Code	Process Connection	Depth
02	¼ NPT	3.15 [80.0]
04	½ NPT	3.20 [81.2]
09	¼ HP Female	3.20 [81.2]
13	G¼ B	3.07 [77.9]
15	G½ B	3.31 [84.2]
16	M20x1.5	3.31 [84.2]
JP	¼ Tube	3.18 [80.7]
JR	⅜ Tube	3.31 [84.0]
JS	½ Tube	3.34 [84.9]
KA	¼ BSPT or R ¼	3.00 [76.3]
KD	½ BSPT or R ½	3.20 [81.2]

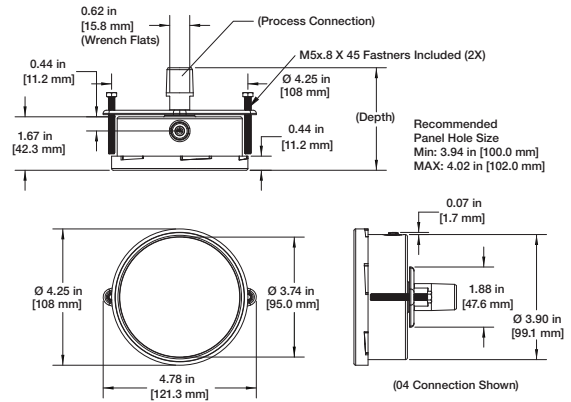
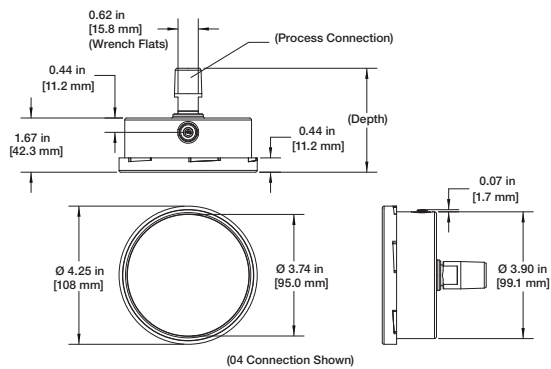

100 mm center back connect - panel mount, case		
Connection Code	Process Connection	Depth
02	¼ NPT	3.15 [80.0]
04	½ NPT	3.20 [81.2]
09	¼ HP Female	3.20 [81.2]
13	G¼ B	3.07 [77.9]
15	G½ B	3.31 [84.2]
16	M20x1.5	3.31 [84.2]
JP	¼ Tube	3.18 [80.7]
JR	⅜ Tube	3.31 [84.0]
JS	½ Tube	3.34 [84.9]
KA	¼ BSPT or R ¼	3.00 [76.3]
KD	½ BSPT or R ½	3.20 [81.2]

100 mm center back connect - front flange		
Connection Code	Process Connection	Depth
02	¼ NPT	3.15 [80.0]
04	½ NPT	3.20 [81.2]
09	¼ HP Female	3.20 [81.2]
13	G¼ B	3.07 [77.9]
15	G½ B	3.31 [84.2]
16	M20x1.5	3.31 [84.2]
JP	¼ Tube	3.18 [80.7]
JR	⅜ Tube	3.31 [84.0]
JS	½ Tube	3.34 [84.9]
KA	¼ BSPT or R ¼	3.00 [76.3]
KD	½ BSPT or R ½	3.20 [81.2]

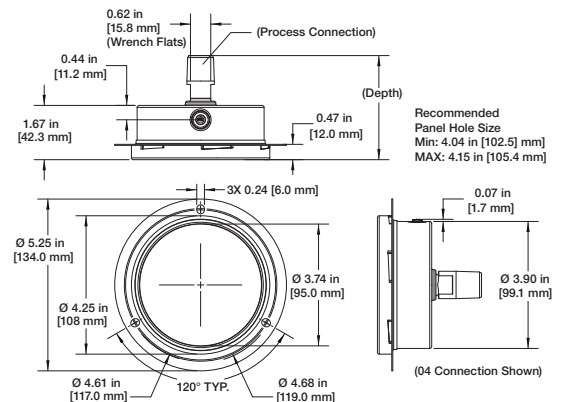
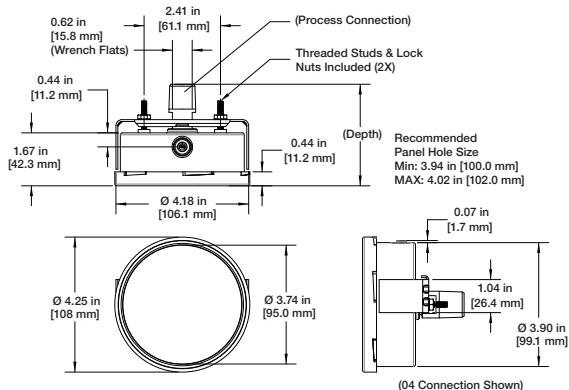

Data Sheet

8009S Pressure Gauge

DIMENSIONS in [] are millimeters

For reference only, consult Ashcroft for specific dimensional drawings

100 mm center back connect - panel mount, socket, front flange		
Connection Code	Process Connection	Depth
02	¼ NPT	3.15 [80.0]
04	½ NPT	3.20 [81.2]
09	¼ HP Female	3.20 [81.2]
13	G¼ B	3.07 [77.9]
15	G½ B	3.31 [84.2]
16	M20x1.5	3.31 [84.2]
JP	¼ Tube	3.18 [80.7]
JR	⅜ Tube	3.31 [84.0]
JS	½ Tube	3.34 [84.9]
KA	¼ BSPT or R ¼	3.00 [76.3]
KD	½ BSPT or R ½	3.20 [81.2]

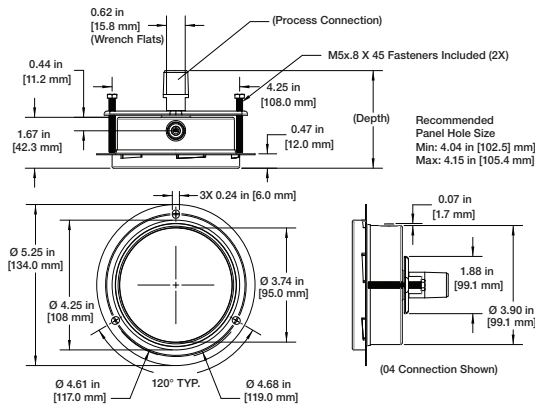

100 mm center back connect - panel mount, case, front flange		
Connection Code	Process Connection	Depth
02	¼ NPT	3.15 [80.0]
04	½ NPT	3.20 [81.2]
09	¼ HP Female	3.20 [81.2]
13	G¼ B	3.07 [77.9]
15	G½ B	3.31 [84.2]
16	M20x1.5	3.31 [84.2]
JP	¼ Tube	3.18 [80.7]
JR	⅜ Tube	3.31 [84.0]
JS	½ Tube	3.34 [84.9]
KA	¼ BSPT or R ¼	3.00 [76.3]
KD	½ BSPT or R ½	3.20 [81.2]

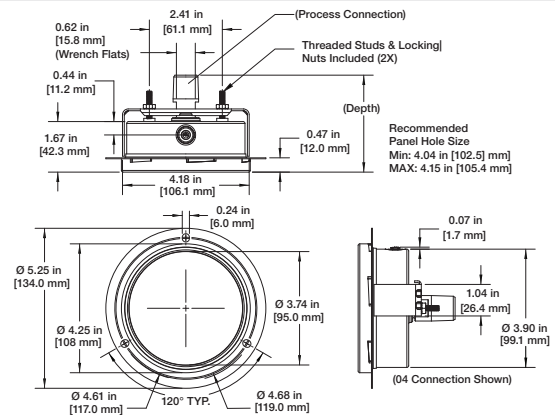

100 mm center back connect - panel mount, socket, trim ring		
Connection Code	Process Connection	Depth
02	¼ NPT	3.15 [80.0]
04	½ NPT	3.20 [81.2]
09	¼ HP Female	3.20 [81.2]
13	G¼ B	3.07 [77.9]
15	G½ B	3.31 [84.2]
16	M20x1.5	3.31 [84.2]
JP	¼ Tube	3.18 [80.7]
JR	⅜ Tube	3.31 [84.0]
JS	½ Tube	3.34 [84.9]
KA	¼ BSPT or R ¼	3.00 [76.3]
KD	½ BSPT or R ½	3.20 [81.2]

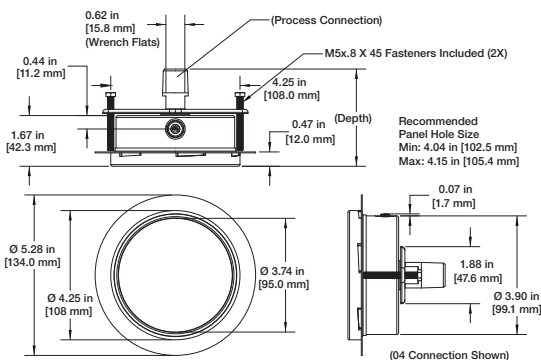

100 mm center back connect - panel mount, case, trim ring		
Connection Code	Process Connection	Depth
02	¼ NPT	3.15 [80.0]
04	½ NPT	3.20 [81.2]
09	¼ HP Female	3.20 [81.2]
13	G¼ B	3.07 [77.9]
15	G½ B	3.31 [84.2]
16	M20x1.5	3.31 [84.2]
JP	¼ Tube	3.18 [80.7]
JR	⅜ Tube	3.31 [84.0]
JS	½ Tube	3.34 [84.9]
KA	¼ BSPT or R ¼	3.00 [76.3]
KD	½ BSPT or R ½	3.20 [81.2]

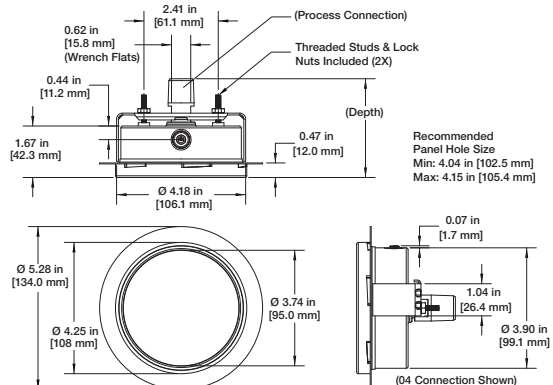

8009S Pressure Gauge

DIMENSIONS in [] are millimeters

For reference only, consult Ashcroft for specific dimensional drawings

100 mm center back connect - rear flange

Connection Code	Process Connection	Depth
02	¼ NPT	3.15 [80.0]
04	½ NPT	3.20 [81.2]
09	¼ HP Female	3.20 [81.2]
13	G¼ B	3.07 [77.9]
15	G½ B	3.31 [84.2]
16	M20x1.5	3.31 [84.2]
JP	¼ Tube	3.18 [80.7]
JR	⅜ Tube	3.31 [84.0]
JS	½ Tube	3.34 [84.9]
KA	¼ BSPT or R ¼	3.00 [76.3]
KD	½ BSPT or R ½	3.20 [81.2]

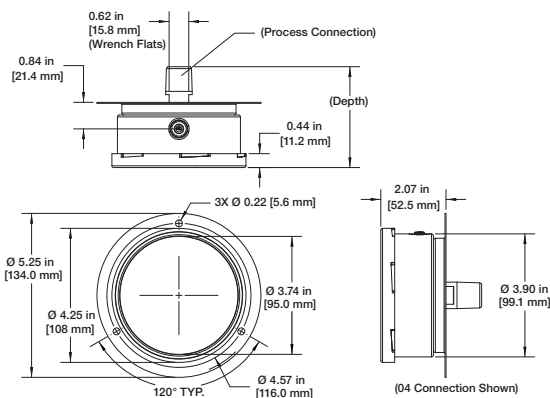

63 mm lower connect - stem mount

Connection Code	Process Connection	Height
01	¼ NPT	3.81 [96.6]
02	¼ NPT	3.86 [98.1]
13	G¼ B	3.86 [98.0]
41	M14x1.5	3.90 [99.0]
EJ	JIC #4	3.81 [96.6]
JP	¼ Tube	3.97 [100.8]
JR	⅜ Tube	4.10 [104.1]
JS	½ Tube	4.23 [107.4]
KA	¼ BSPT	3.81 [96.6]
RW	SAE ⅜-20	3.97 [100.8]

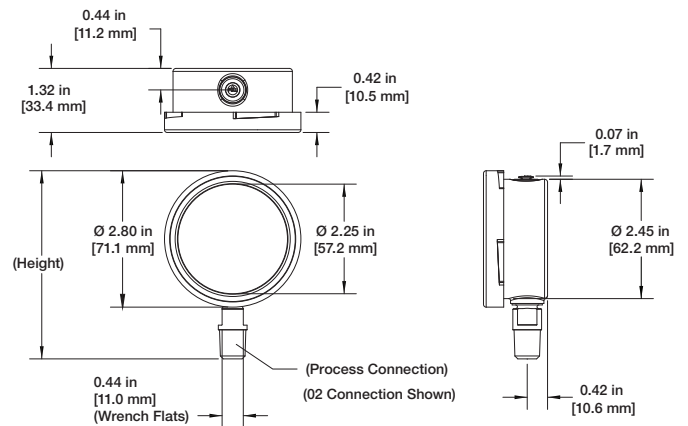

63 mm lower connect - rear flange

Connection Code	Process Connection	Height
01	¼ NPT	3.81 [96.6]
02	¼ NPT	3.86 [98.1]
13	G¼ B	3.86 [98.0]
41	M14x1.5	3.90 [99.0]
EJ	JIC #4	3.81 [96.6]
JP	¼ Tube	3.97 [100.8]
JR	⅜ Tube	4.10 [104.1]
JS	½ Tube	4.23 [107.4]
KA	¼ BSPT	3.81 [96.6]
RW	SAE ⅜-20	3.97 [100.8]

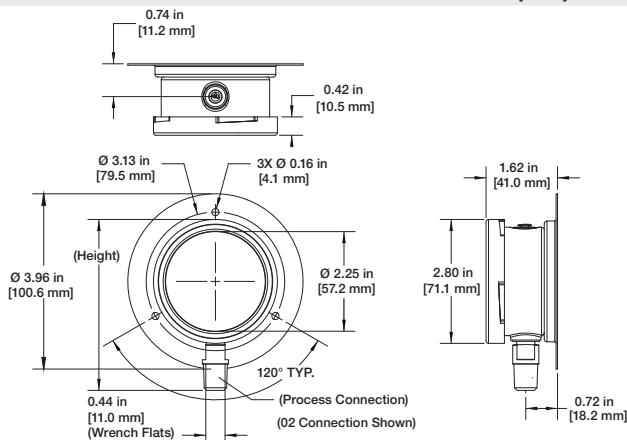

Data Sheet

8009S Pressure Gauge

DIMENSIONS in [] are millimeters

For reference only, consult Ashcroft for specific dimensional drawings

63 mm lower back connect - stem mount

Connection Code	Process Connection	Depth
01	1/8 NPT	2.50 [63.4]
02	1/4 NPT	2.55 [64.8]
13	G1/4 B	2.55 [64.7]
41	M14x1.5	2.59 [65.7]
EJ	JIC #4	2.50 [63.4]
JP	1/4 Tube	2.66 [67.5]
JR	3/8 Tube	2.79 [70.8]
JS	1/2 Tube	2.92 [74.1]
KA	1/4 BSPT	2.50 [63.4]
RW	SAE 1/16-20	2.66 [67.5]

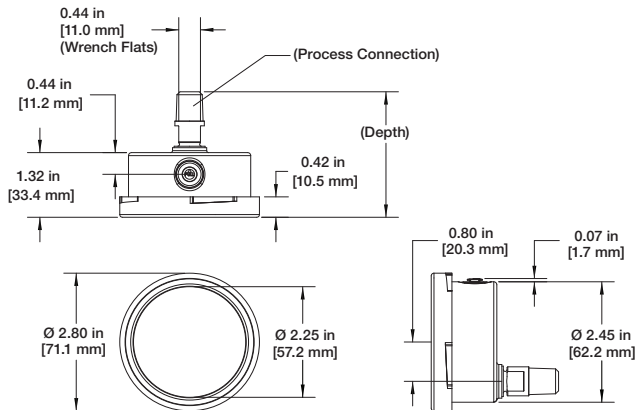

63 mm lower back connect - panel mount, case

Connection Code	Process Connection	Depth
01	1/8 NPT	2.50 [63.4]
02	1/4 NPT	2.55 [64.8]
13	G1/4 B	2.55 [64.7]
41	M14x1.5	2.59 [65.7]
EJ	JIC #4	2.50 [63.4]
JP	1/4 Tube	2.66 [67.5]
JR	3/8 Tube	2.79 [70.8]
JS	1/2 Tube	2.92 [74.1]
KA	1/4 BSPT	2.50 [63.4]
RW	SAE 1/16-20	2.66 [67.5]

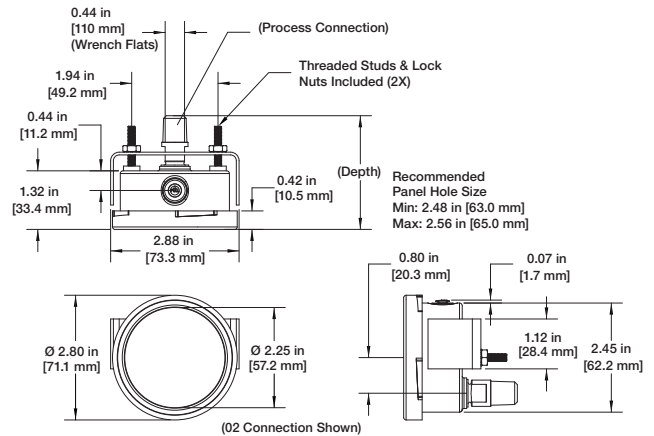

63 mm lower back connect - front flange

Connection Code	Process Connection	Depth
01	1/8 NPT	2.50 [63.4]
02	1/4 NPT	2.55 [64.8]
13	G1/4 B	2.55 [64.7]
41	M14x1.5	2.59 [65.7]
EJ	JIC #4	2.50 [63.4]
JP	1/4 Tube	2.66 [67.5]
JR	3/8 Tube	2.79 [70.8]
JS	1/2 Tube	2.92 [74.1]
KA	1/4 BSPT	2.50 [63.4]
RW	SAE 1/16-20	2.66 [67.5]

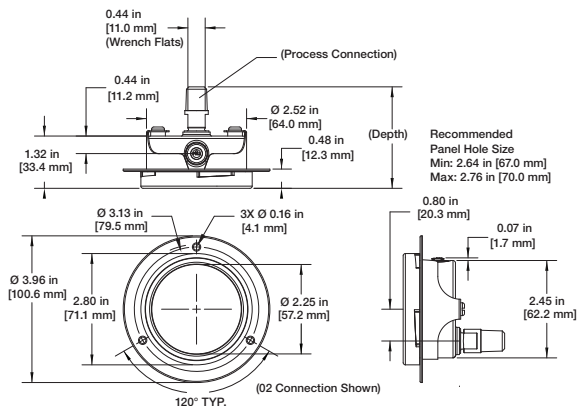

63 mm lower back connect - panel mount, case, front flange

Connection Code	Process Connection	Depth
01	1/8 NPT	2.50 [63.4]
02	1/4 NPT	2.55 [64.8]
13	G1/4 B	2.55 [64.7]
41	M14x1.5	2.59 [65.7]
EJ	JIC #4	2.50 [63.4]
JP	1/4 Tube	2.66 [67.5]
JR	3/8 Tube	2.79 [70.8]
JS	1/2 Tube	2.92 [74.1]
KA	1/4 BSPT	2.50 [63.4]
RW	SAE 1/16-20	2.66 [67.5]

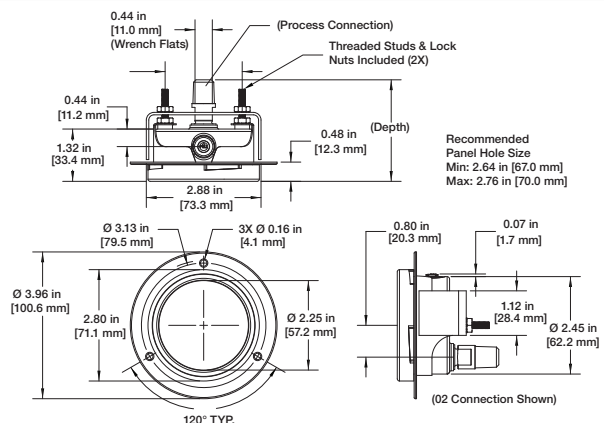

8009S Pressure Gauge

DIMENSIONS in [] are millimeters

For reference only, consult Ashcroft for specific dimensional drawings

63 mm lower back connect - panel mount, case, trim ring

Connection Code	Process Connection	Depth
01	¼ NPT	2.50 [63.4]
02	¼ NPT	2.55 [64.8]
13	G¼ B	2.55 [64.7]
41	M14x1.5	2.59 [65.7]
EJ	JIC #4	2.50 [63.4]
JP	¼ Tube	2.66 [67.5]
JR	¾ Tube	2.79 [70.8]
JS	½ Tube	2.92 [74.1]
KA	¼ BSPT	2.50 [63.4]
RW	SAE ¼-20	2.66 [67.5]

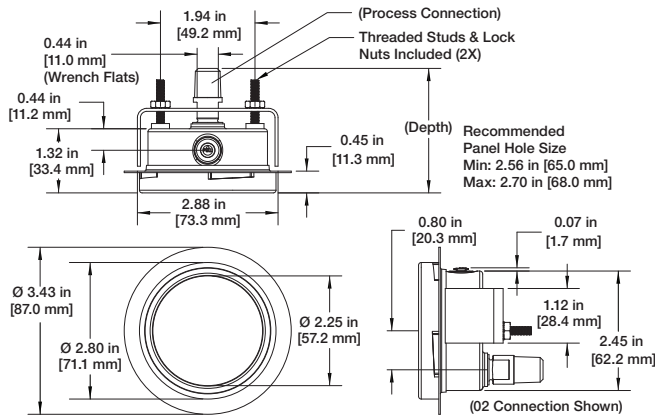

63 mm lower back connect - rear flange

Connection Code	Process Connection	Depth
01	¼ NPT	2.50 [63.4]
02	¼ NPT	2.55 [64.8]
13	G¼ B	2.55 [64.7]
41	M14x1.5	2.59 [65.7]
EJ	JIC #4	2.50 [63.4]
JP	¼ Tube	2.66 [67.5]
JR	¾ Tube	2.79 [70.8]
JS	½ Tube	2.92 [74.1]
KA	¼ BSPT	2.50 [63.4]
RW	SAE ¼-20	2.66 [67.5]

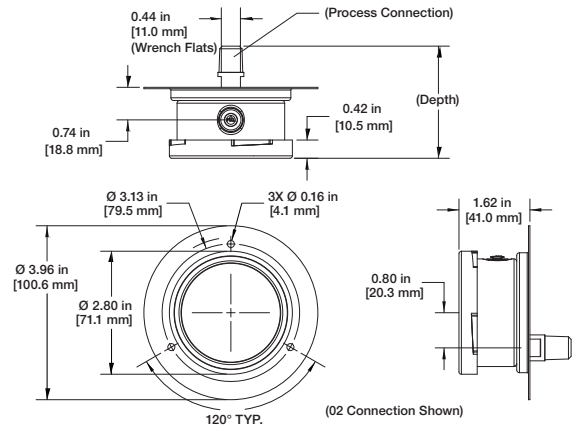

63 mm center back connect - stem mount

Connection Code	Process Connection	Depth
01	¼ NPT	2.50 [63.4]
02	¼ NPT	2.55 [64.8]
13	G¼ B	2.55 [64.7]
41	M14x1.5	2.59 [65.7]
EJ	JIC #4	2.50 [63.4]
JP	¼ Tube	2.66 [67.5]
JR	¾ Tube	2.79 [70.8]
JS	½ Tube	2.92 [74.1]
KA	¼ BSPT	2.50 [63.4]
RW	SAE ¼-20	2.66 [67.5]

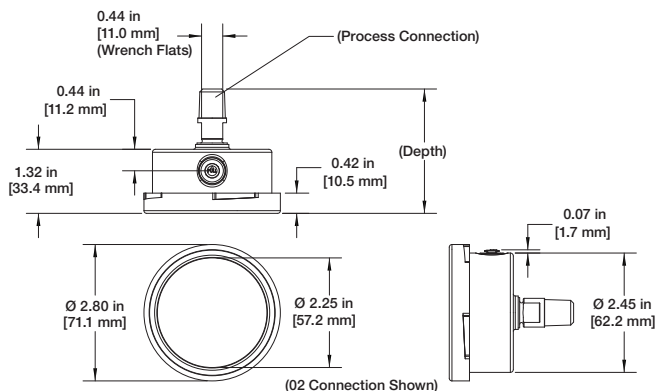

63 mm center back connect - panel mount, socket

Connection Code	Process Connection	Depth
01	¼ NPT	2.50 [63.4]
02	¼ NPT	2.55 [64.8]
13	G¼ B	2.55 [64.7]
41	M14x1.5	2.59 [65.7]
EJ	JIC #4	2.50 [63.4]
JP	¼ Tube	2.66 [67.5]
JR	¾ Tube	2.79 [70.8]
JS	½ Tube	2.92 [74.1]
KA	¼ BSPT	2.50 [63.4]
RW	SAE ¼-20	2.66 [67.5]

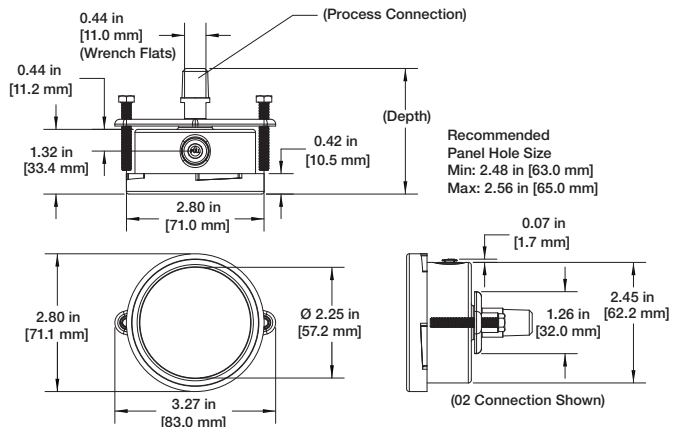

Data Sheet

8009S Pressure Gauge

DIMENSIONS in [] are millimeters

For reference only, consult Ashcroft for specific dimensional drawings

63 mm center back connect - panel mount, case

Connection Code	Process Connection	Depth
01	¼ NPT	2.50 [63.4]
02	¼ NPT	2.55 [64.8]
13	G¼ B	2.55 [64.7]
41	M14x1.5	2.59 [65.7]
EJ	JIC #4	2.50 [63.4]
JP	¼ Tube	2.66 [67.5]
JR	¾ Tube	2.79 [70.8]
JS	½ Tube	2.92 [74.1]
KA	¼ BSPT	2.50 [63.4]
RW	SAE ¼"-20	2.66 [67.5]

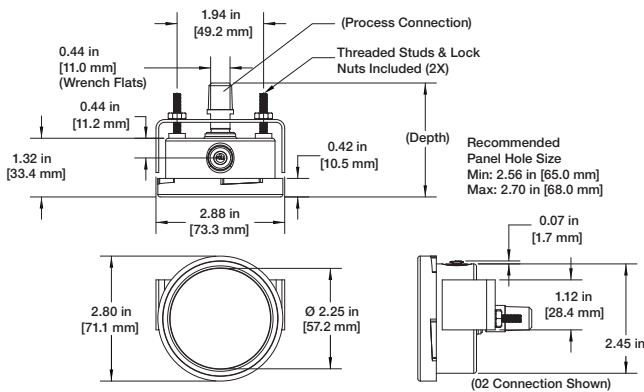

63 mm center back connect - front flange

Connection Code	Process Connection	Depth
01	¼ NPT	2.50 [63.4]
02	¼ NPT	2.55 [64.8]
13	G¼ B	2.55 [64.7]
41	M14x1.5	2.59 [65.7]
EJ	JIC #4	2.50 [63.4]
JP	¼ Tube	2.66 [67.5]
JR	¾ Tube	2.79 [70.8]
JS	½ Tube	2.92 [74.1]
KA	¼ BSPT	2.50 [63.4]
RW	SAE ¼"-20	2.66 [67.5]

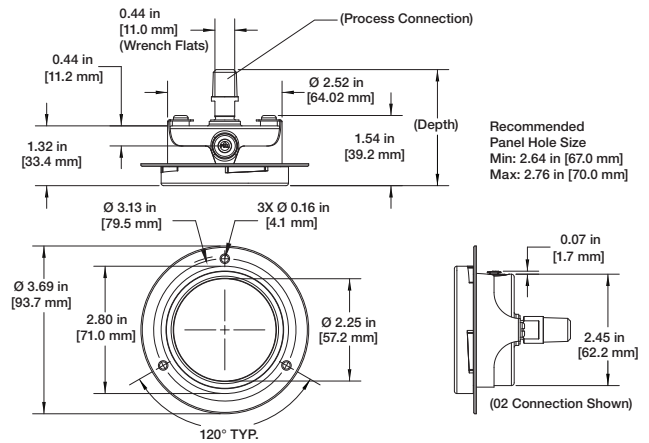

63 mm center back connect - panel mount case, front flange

Connection Code	Process Connection	Depth
01	¼ NPT	2.50 [63.4]
02	¼ NPT	2.55 [64.8]
13	G¼ B	2.55 [64.7]
41	M14x1.5	2.59 [65.7]
EJ	JIC #4	2.50 [63.4]
JP	¼ Tube	2.66 [67.5]
JR	¾ Tube	2.79 [70.8]
JS	½ Tube	2.92 [74.1]
KA	¼ BSPT	2.50 [63.4]
RW	SAE ¼"-20	2.66 [67.5]

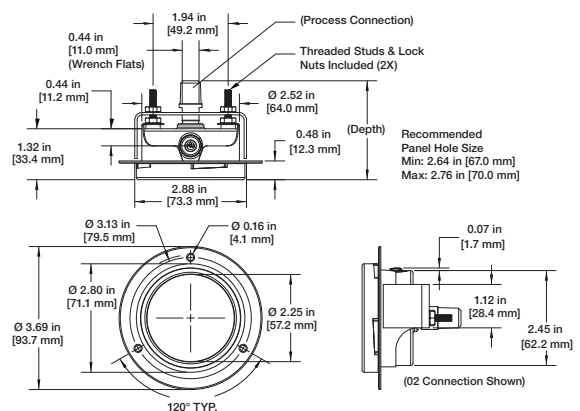

8009S Pressure Gauge

DIMENSIONS in [] are millimeters

For reference only, consult Ashcroft for specific dimensional drawings

63 mm center back connect - panel mount socket, trim ring

Connection Code	Process Connection	Depth
01	¼ NPT	2.50 [63.4]
02	¼ NPT	2.55 [64.8]
13	G¼ B	2.55 [64.7]
41	M14x1.5	2.59 [65.7]
EJ	JIC #4	2.50 [63.4]
JP	¼ Tube	2.66 [67.5]
JR	¾ Tube	2.79 [70.8]
JS	½ Tube	2.92 [74.1]
KA	¼ BSPT	2.50 [63.4]
RW	SAE ¼ ₁₆ -20	2.66 [67.5]

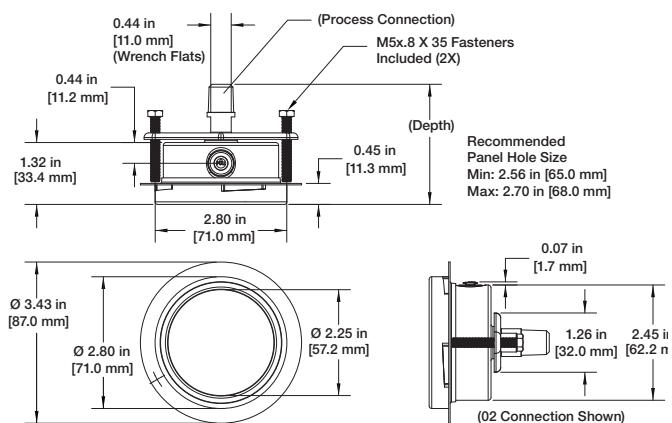

63 mm center back connect - panel mount, case, trim ring

Connection Code	Process Connection	Depth
01	¼ NPT	2.50 [63.4]
02	¼ NPT	2.55 [64.8]
13	G¼ B	2.55 [64.7]
41	M14x1.5	2.59 [65.7]
EJ	JIC #4	2.50 [63.4]
JP	¼ Tube	2.66 [67.5]
JR	¾ Tube	2.79 [70.8]
JS	½ Tube	2.92 [74.1]
KA	¼ BSPT	2.50 [63.4]
RW	SAE ¼ ₁₆ -20	2.66 [67.5]

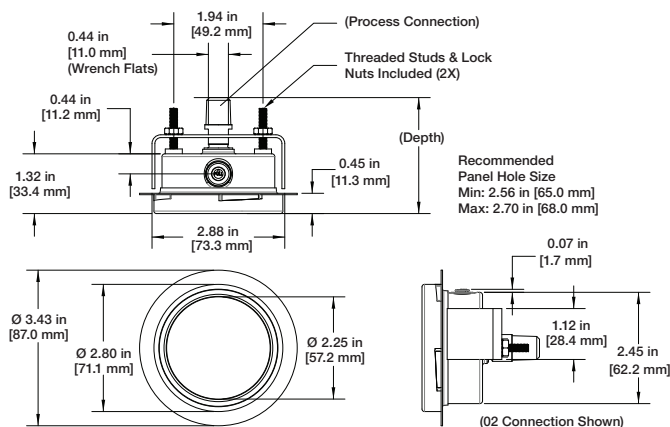

63 mm center back connect - rear flange

Connection Code	Process Connection	Depth
01	¼ NPT	2.50 [63.4]
02	¼ NPT	2.55 [64.8]
13	G¼ B	2.55 [64.7]
41	M14x1.5	2.59 [65.7]
EJ	JIC #4	2.50 [63.4]
JP	¼ Tube	2.66 [67.5]
JR	¾ Tube	2.79 [70.8]
JS	½ Tube	2.92 [74.1]
KA	¼ BSPT	2.50 [63.4]
RW	SAE ¼ ₁₆ -20	2.66 [67.5]

