

## Type 1327D Pressure Gauge Comparator

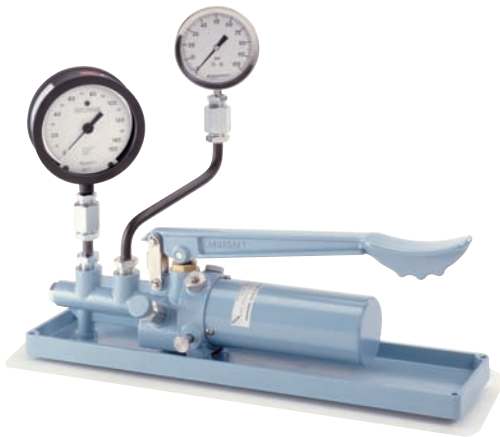

### APPLICATION

- *For pressure generating applications requiring a manually operated hydraulic pump*

### FEATURES

- *Operating Pressure: 0-10,000 psi maximum (0-60,000 kPa)*
- *Operating Media:*
  - *Standard: SAE 20 weight automotive machine oil*
  - *Optional: Phosphate-based or glycol fluids; Distilled water for oxygen service*
- *O-ring Material:*
  - *Standard: Buna N (D Series)*
  - *Optional: Ethylene Propylene (DH Series)*
- *Reservoir Volume: Approximately 1.5 pints (0.7 liter)*

Many calibration applications require only a quick comparison to a master gauge, without the need for a primary deadweight standard. In these applications the Ashcroft 1327D offers the ideal combination of a reliable pressure source and a proven secondary standard.

The 1327D utilizes the same pump, tools, box and accessories that are used in the 1305D deadweight tester. However, instead of weights and pistons, the 1327D employs from 1 to 4 Ashcroft model 1082 test gauges as comparison masters. These gauges have a dial size of 4½ inches and are accurate to 0.25% of span in compliance with the requirements of ASME (formerly ANSI) B40.1, grade 3A. The Ashcroft 1082 Test Gauge makes the 1327D the perfect choice for the calibration of 1% F.S. industrial service gauges where a 4:1 accuracy ratio must be maintained.

Like the 1305D, the 1327D is available in versions to accommodate either petroleum based oils or glycol and phosphate ester based "hydraulic fluids". In addition, the 1327D can be configured to operate with distilled water for the calibration of oxygen service gauges.

Lightweight and fully portable, the 1327D offers maximum utility in one simple, compact and complete test set.

### SPECIFICATIONS – 1327D

**Accuracy:** 0.25% of gauge span  
**Gauges:** Ashcroft Model 1082(#4384), 4½", ASME B40.1, Grade 3A, temp. compensated. Bourdon tube materials – Bronze or "K" Monel (depending on range) Gauge ranges – (see table)

**Operating Pressure:** 0 to 10,000 psi max. (0 to 70,000 kPa)

**Reservoir Volume:** Approximately 1.5 pints (0.7 liter)

**Pump Body Material:** Aluminum alloy

**Operating Fluid:** 1327D – SAE 20 automotive or machine oil  
 1327DH – Phosphate or glycol base hydraulic fluids  
 1327DO – Distilled water (with sodium molybdate and phosphoric acid additives recommended as corrosion inhibitors)

**O-Ring Seals:** Standard (1327D and 1327DO) – Buna-N  
 Optional (1327DH) – Ethylene Propylene

**Accessories:** Metal carrying and storage box  
 Lower connection offset pipe assembly  
 Back connection pipe  
 Gauge pipe extension assembly  
 ¼ & ½ NPT Female adapters  
 Wrench (1" x 1½")  
 Wrench (¾" x 1")  
 Wrench (¾")  
 Pointer puller set  
 Installation and Operation Manual  
 Spare O-ring kit

**Certification:** Standard – No documentation provided  
 Optional – NIST traceability document provided for each gauge only upon request of "CD-4" certification documents.

### Carrying Case

**Dimensions:** 10 x 10 x 22 (inches)

## Type 1327D Pressure Gauge Comparator

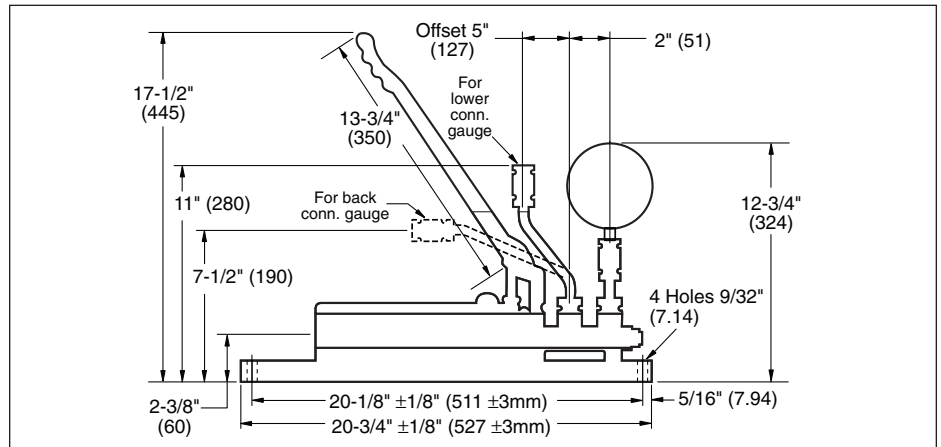

UNIT OF MEASURE	MODEL NUMBER	GAUGE RANGES INCLUDED				NET WEIGHT	
						lbs.	kg.
psig	1327DG-2	0/150	-	-	-	36	16
	1327DG-6	0/150	0/600	-	-	38	17
	1327DG-50	0/150	0/600	0/5000	-	40	18
	1327DG-100	0/150	0/600	0/5000	0/10,000	42	19
kg/cm <sup>2</sup>	1327DMG-10	0/10	-	-	-	36	16
	1327DMG-40	0/10	0/40	-	-	38	17
	1327DMG-250	0/10	0/40	0/250	-	40	18
	1327DMG-600	0/10	0/40	0/250	0/600	42	19
bar	1327DBG-10	0/10	-	-	-	36	16
	1327DBG-40	0/10	0/40	-	-	38	17
	1327DBG-250	0/10	0/40	0/250	-	40	18
	1327DBG-600	0/10	0/40	0/250	0/600	42	19
kPa	1327DAG-1000	0/1000	-	-	-	36	16
	1327DAG-4000	0/1000	0/4000	-	-	38	17
	1327DAG-25,000	0/1000	0/4000	0/25,000	-	40	18
	1327DAG-60,000	0/1000	0/4000	0/25,000	0/60,000	42	19