

# Thermal Flow Transmitter

for Water-Based Liquids



measuring  
•  
monitoring  
•  
analyzing

KAL-A



- Microprocessor-Based Drift Stabilization
- NPT and 3-A Compliant Sanitary Fittings
- No Moving Parts
- Extremely Low Pressure Loss
- Easy to Operate
- Insensitive to Dirt
- 4-20 mA Flow Rate Signal with Optional Switch Output



KOBOLD companies worldwide:

ARGENTINA, AUSTRALIA, AUSTRIA, BELGIUM, BULGARIA, CANADA, CHILE, CHINA, COLOMBIA, CZECH REPUBLIC, EGYPT, FRANCE, GERMANY, HUNGARY, INDIA, INDONESIA, ITALY, MALAYSIA, MEXICO, NETHERLANDS, PERU, POLAND, REPUBLIC OF KOREA, ROMANIA, SINGAPORE, SPAIN, SWITZERLAND, TAIWAN, THAILAND, TUNISIA, TURKEY, UNITED KINGDOM, USA, VIETNAM

KOBOLD Instruments, Inc.  
1801 Parkway View Drive  
Pittsburgh, PA 15205  
Main Office:  
1.800.998.1020  
1.412.788.4890  
info@koboldusa.com  
www.koboldusa.com



**Description**

The KAL-A uses the calorimetric principle to continuously monitor the flow of low viscosity, water-based media. Flow rate is transmitted via a 4-20 mA output while an optional switch provides an alarm function. The transmission capability of the KAL-A is made possible by the high degree of temperature stability provided by its "intelligent" microprocessor based design. This digital approach also enables the use of a single RTD element to both heat the probe tip and measure temperature. Integrating the heating measuring functions allows the probe to be machined into a single, continuous, protrusion-free surface. The absence of protrusions prevents contamination from building up on the probe tip. These design enhancements improve the KAL's performance in two ways: sensing stability is increased because contaminant cannot thermally isolate the probe from the liquid, and system down-time associated with probe cleaning is dramatically decreased. Stability and reliability are a KOBOLD KAL trademark.



**Operation**

The KAL design is based on the time proven calorimetric principle. The sensor is internally heated to a few degrees above the temperature of the media. Flow causes removal of heat from the sensor, resulting in a cooling effect. The rate of cooling is a measure of the flow velocity. The microprocessor-based design of the KAL distinguishes it from the competition. Full temperature compensation of the flow rate is readily obtained through a simple, one-time, calibration procedure. This assures elimination of flow rate reading drift caused by temperature variations in the process liquid.

**Temperature Compensation**

The KOBOLD KAL flow products use a microprocessor to compensate for temperature changes through use of an internal lookup table. End-users can easily adapt the equipment to their unique installations. Unlike conventional calorimetric flow switches, the technically advanced design of the KAL provides a flow reading which is largely unaffected by temperature.

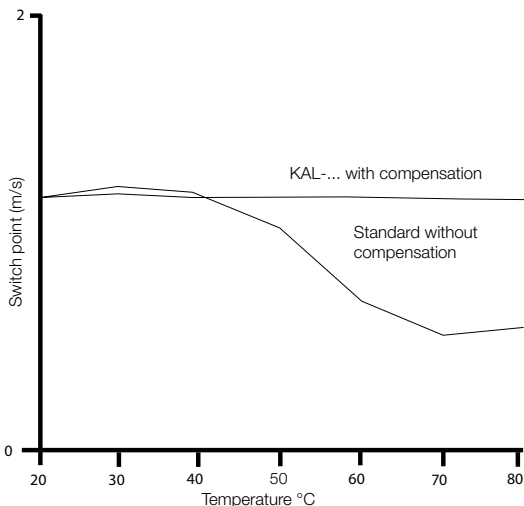

**KAL Timing - Heating and Measuring Cycle**

Typical Flow Measuring Cycle

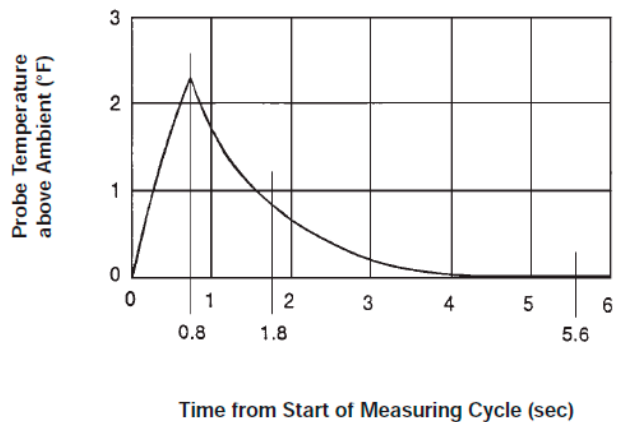

**Operating Behavior**

1. At t=0, the probe temperature is recorded. This reading represents the ambient liquid temperature.
2. Still at t=0, the KAL begins heating the probe.
3. At t=0.8 seconds, the heating cycle ends and the KAL begins monitoring the probe temperature.
4. At t=1.8 seconds, a temperature reading is taken and compared to the t=0.8 second temperature. The rate of cooling is calculated and compared to a Cooling Rate vs Flow Rate table specific to the ambient temperature recorded at t=0.
5. The probe is allowed to cool until t=5.6 seconds. A temperature reading is taken and compared to the initial t=0 reading. If the temperatures are equal (or nearly so), the flow reading is determined valid and passes through to the KAL output. If the temperatures are not equal, the KAL waits another 5.6 sec, and Step 5 repeats.



**Specifications**

<b>Sensing Range:</b>	0.04...2 m/s
<b>Media:</b>	Water-based Liquids
<b>Response Time</b>	
<b>Typical:</b>	5.6...12 seconds
<b>Fittings</b>	
<b>Standard:</b>	1/2" or 3/4" NPT
<b>Sanitary:</b>	1-1/2" Tri-Clamp®, 3-A Approved
<b>Flow Rate Indication:</b>	Trend Display with 8 Red LEDs
<b>Wetted Parts</b>	
<b>Standard:</b>	304 SS or 316-Ti SS
<b>Sanitary:</b>	316L
<b>Temperature Rating</b>	
<b>Operating:</b>	0...176 °F
<b>CIP:</b>	280 °F (non-operating)
<b>Maximum Pressure</b>	
<b>Threaded:</b>	1450 PSIG
<b>Sanitary:</b>	600 PSIG or per Clamp Rating
<b>Housing</b>	
<b>Standard:</b>	IP 65
<b>Sanitary:</b>	IP 65
<b>Power Requirements</b>	
<b>Supply Voltage:</b>	24 V <sub>DC</sub> ± 2 V <sub>DC</sub>
<b>Current Draw:</b>	300 mA Max.
<b>Analog Output</b>	
<b>Signal Type:</b>	4-20 mA, 3-wire into 500 Ω max.
<b>Linearity:</b>	± 10% of Full Scale
<b>Repeatability:</b>	± 1% of Full Scale
<b>Zero Adjustment:</b>	0...75% of Range
<b>Span Adjustment:</b>	25...100% of Range
<b>Optional Switch Characteristics</b>	
<b>Adjustment:</b>	By Potentiometer
<b>Output:</b>	PNP/NPN Open Collector
<b>Max. Current:</b>	400 mA
<b>Max. Voltage:</b>	24 V <sub>DC</sub>
<b>Status Indicator:</b>	Bi-colored LED



**Approximate Switch Points at Various Pipe Diameters**

Nominal ID (inch)	Range Water (GPM)	Nominal ID (inch)	Range Water (GPM)
1/2	0.08...4.0	4	6.0...250
3/4	0.2...9.0	6	12...575
1	0.4...16	8	20...1025
1 1/4	0.5...25	10	35...1600
1 1/2	0.8...36	12	50...2300
2	1.3...64	16	85...4100
2 1/2	2.0...100	20	130...6400
3	3.0...140		

**Note:**

The approximate flow ranges specified in the table above have been calculated for each pipe diameter from the known flow velocity range of the KAL. It must be noted that flow in pipes is non-uniform across the pipe cross-section and approaches zero at the pipe wall. This means that, in practice, the depth of installation of the probe, the internal pipe diameter, and the flow profile of the liquid in the pipe can interact to produce very significant deviations from the flow ranges in this data sheet.

For correct operation of the KAL-A thermal flow transmitter, the tip of the flow sensor must be located sufficiently into the flow stream of the process to sense the liquid flow. Therefore it is very important to consider the sensor's insertion depth and how it is installed in the process pipe. If the sensor tip is not adequately immersed into the flow stream, the sensor will not measure flow rate correctly, or worst case will not detect any flow at all. Ideally for correct detection, we recommend the sensor tip be located at a distance from the pipe wall equal to 20% of the internal cross-section diameter of the pipe. Note that NPT fittings are tapered, and consideration should be given to the fact that when installed together, NPT mating fittings will not fully thread down to the bottom of the female connection.

**KAL-A Order Details** (Example: **KAL-7315C**)

Fitting	Model (304 SS)	Model (316-Ti SS)	Model (316L SS)	Options
1/2" NPT	<b>KAL-7215</b>	<b>KAL-7315</b>	-	..C = 1/2" NPT Conduit Electrical Connection
3/4" NPT	-	<b>KAL-7320</b>	-	..EP = Extended Probe*
1-1/2" Tri-Clamp®	-	-	<b>KAL-7340S</b>	..M12 = Plug Connector with 6 ft. M-12 Mating Cable
				..P = N/O, PNP/NPN Switch
				..PK = N/C, PNP/NPN Switch

\*specify probe length on your order (NPT models only)



# Thermal Flow Transmitter Model KAL-A

## Dimensions

### Standard Version

1/2" Model

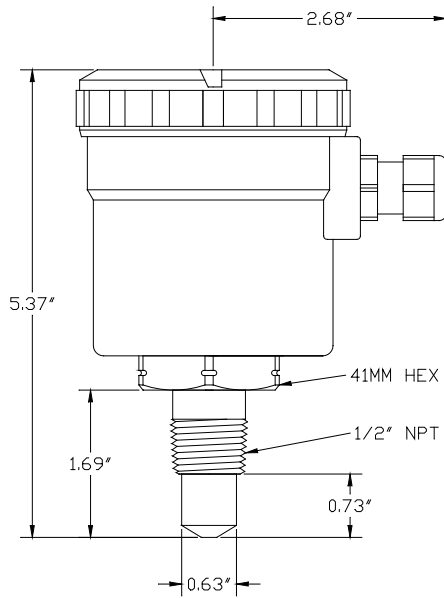

3/4" Model

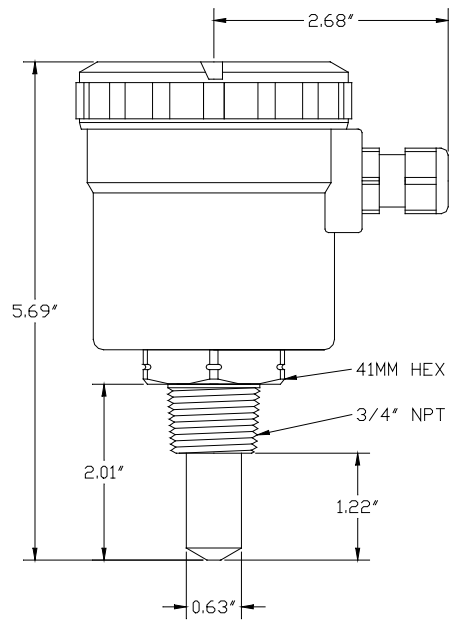

### Sanitary Version

