

Standard thermometer Models CTP2000 and CTP9000

WIKA data sheet CT 61.10

Applications

- Comparative calibration in dry well calibrators, tube furnaces and liquid baths

Special features

- High stability
- Low drift, long service life
- Wide temperature range

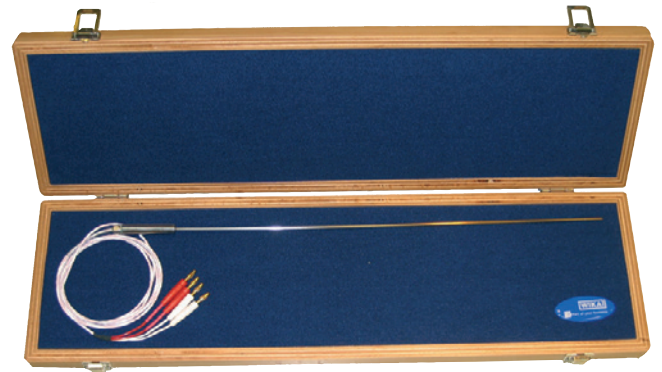

Platinum resistance thermometer model CTP2000

Description

Calibration by means of an external standard thermometer

The WIKA standard thermometers are particularly suited for applications in industrial laboratories. They enable easy comparative calibration in our baths, in tube furnace and in dry well calibrators.

The use of an external reference thermometer is recommended, particularly for the calibration of short temperature sensors. Thus the errors due to the radial and axial temperature distribution in the temperature conditioning unit are considerably reduced.

For calibration, the test items and the standard thermometer are brought to the same temperature in a temperature conditioning unit.

As soon as a stable temperature is reached, the test items are read or their output signals are measured (resistance, thermoelectric voltage, standard signal) and compared with the standard thermometer.

Using this comparison method, the measuring uncertainty can be considerably reduced because not only the display of the temperature conditioning unit is taken into consideration.

Models

Platinum resistance thermometers model CTP2000

Features

The measuring resistor consists of a platinum winding of highest purity.

All parts are pre-aged in order to remove contamination and distortions.

Measuring technology

The 4-wire design offers an optimum connection solution for resistance thermometers. The measuring result is affected neither by the lead resistances nor the temperature-dependant fluctuations.

The electrical connections are welded in order to minimise the transition resistance. The connecting wires are bound in a 2 m long, shielded connection cable.

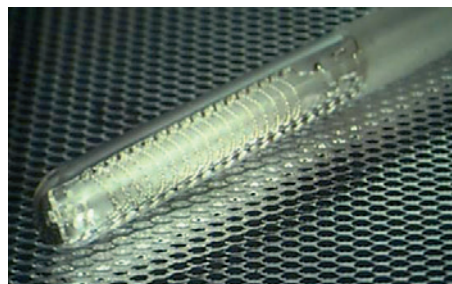

Principle of a platinum winding

Thermocouple model CTP9000

Features

The standard thermometer is a type S element whose nominal composition consists of Platinum-10 % Rhodium (positive leg) against Platinum (negative leg) and belongs to the group of noble thermocouples.

It is characterised by its high stability.

The quality of the thermowell used is essential for stability at high temperatures. For this reason, the high-purity aluminium oxide ceramic C 799 is used.

The type S thermocouple, besides the low ageing drift, also offers the advantage of a low basic tolerance.

Measuring technology

During measurement it must be ensured that the compensating leads from the measuring point to the cold junction consist of substitute materials which have, in a limited temperature range, the same thermoelectric properties as the materials of the thermocouple. Therefore, at this transition, there is no thermoelectric voltage.

This voltage is only generated at the point where the compensating leads are connected to normal copper leads.



Thermocouple model CTP9000

Calibration

Your standard thermometer should be calibrated once a year.

If it is subject to high mechanical stresses, it should be calibrated immediately to guarantee the measuring uncertainty.

Platinum resistance thermometer

Specifications	Model CTP2000
Temperature range	-200 ... +450 °C
Nominal resistance	100 Ω
Temperature coefficient	$\alpha = 0.003850 \text{ 1/K}$
Stability	< 50 mK after 100 h at 450 °C < 20 mK after 100 h at 300 °C
Dimensions, d x l	4 x 500 mm
Immersion tube material	stainless steel
Sensor connection	4-wire connection
Measuring line	2 m cable stripped and tin-coated
Connector	4 mm banana plug

Thermocouple

Specifications	Model CTP9000
Temperature range	0 ... 1,300 °C
Thermocouple	Type S per IEC 584, PtRh 10 % Pt
Tolerance	Class 1
Stability	< 0.5 after 250 h at 1,300 °C
Wire size, d x l	0.5 x 1,500 mm
Outer dimensions, d x l	7 x 600 mm
Immersion tube material	Ceramic C 799
Measuring line	800 mm with 4 mm banana plug

Scope of delivery

- Thermometer
- Calculation of the characteristic constant and table $R(t_{90})$ degree by degree

Options

- Transport case
- DKD/DAkkS calibration for 6 temperatures
- Cold junction in the metal tube (CTP9000)
outer dimensions: d x l = 6 mm x 250 mm
measuring line: 2 m PVC cable, with 4 mm banana plug

Schematic representation of the connections

Resistance thermometer

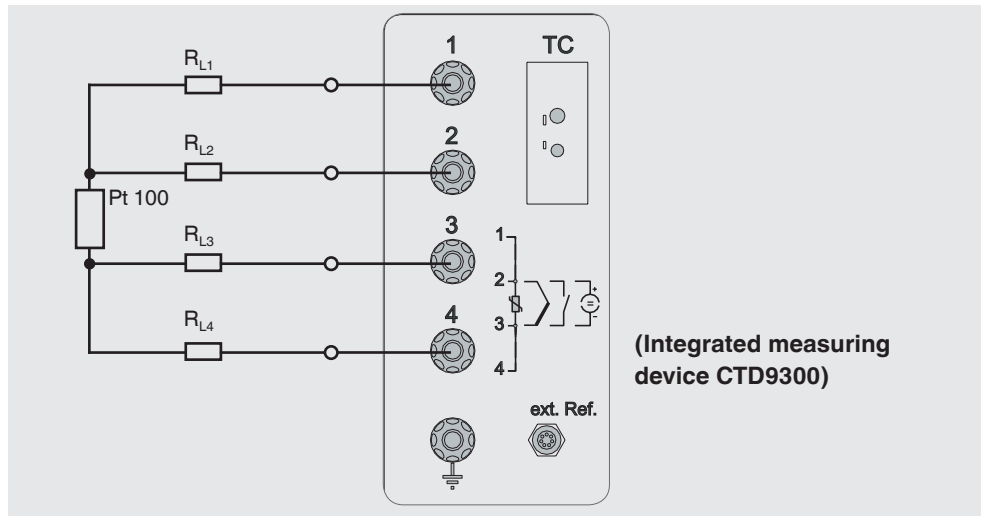

Thermocouples

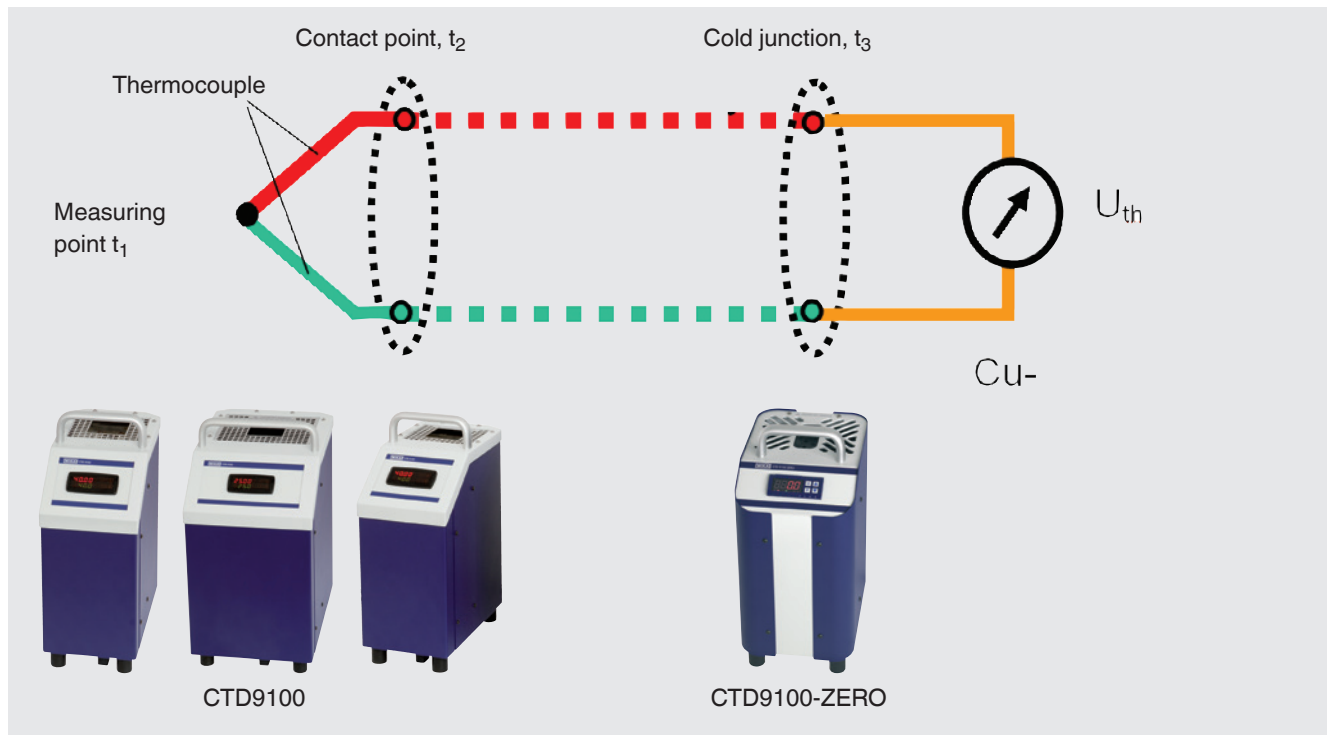

Ordering information

Model / calibration / calculation of constant / transport case / cold junction / additional order details

© 2008 WIKA Alexander Wiegand SE & Co. KG, all rights reserved.
The specifications given in this document represent the state of engineering at the time of publishing.
We reserve the right to make modifications to the specifications and materials.



WIKAL
WIKAL Alexander Wiegand SE & Co. KG
Alexander-Wiegand-Straße 30
63911 Klingenberg/Germany
Tel. +49 9372 132-0
Fax +49 9372 132-406
info@wika.de
www.wika.de